

■ Installation, Operation & Maintenance Manual

For Modentic Multi-port Ball Valve Series

Caution:

Please read these instructions carefully and completely before installation. With the correct installation and maintenance, Modentic valves offer you a long, trouble-free service. The most important thing is to keep off the injury to the personnel and the damage to the equipment.

Safety Precautions:

1. Ball valves are pressure equipment; therefore the appropriate safety measures have to taken into account.
2. Any alterations on the valves and the documents without prior approval from Modentic with formal documentation are not permitted and might result in the huge danger.
3. All valves are designed for use within the limits specified herein and described on the valve body. Exceeding these specified limits is to be considered misuse and can lead to serious injuries and/or damage to the installation and environment.
4. When personnel are maintaining a valve, proper eye, head and whole body protection, and protective clothing should always be utilized. The most important thing is to keep off the injury to the personnel and the damage to the equipment.
5. All of the valves should arrive in the open position at the installation site.
6. There is the possibility that the (dangerous) pressurized fluid or gas could be trapped in the cavity of the valve, make sure this is released safely by partly opening the valve.
7. When the valves are operated on low or elevated temperature, operating personnel must take special care to avoid injuries.
8. The valve body rating can be higher than the seat rating. Valve surface temperature may become extremely hot or cold due to the ambient or operating conditions. Prevent any type of direct contact with the valve that may harm the workers.
9. Valves and accessories must not be used as a sole support of piping or human weight.
10. Safety accessories such as safety relief (overpressure) valves are the responsibility of the system designer.
11. It is the user/system designer's responsibility to use insulation in high temperature applications.
12. Do not disassemble the pneumatic actuator with pressure loaded, warranty will be invalid for inappropriate disassembling.

General:

1. Valve pressure varies under different models, sizes, working temperatures, and the materials of the main parts. Please verify the application within the limits specified herein and as described on the valve body or name plate from Modentic.
2. Any ball valve is a pressure containing part of the installation with an operational function, maintenance personnel must take this into consideration, therefore the appropriate safety measures have to be taken into account, it is necessary to wear the protective equipments and take appropriate precautions to safeguard against possible injury.
3. Always use Modentic recommended spare parts for maintenance and replacement.
4. Valve Marking:

All the marking information should be cast on the body, or on a metal plate which is spot-welded to the body.

PED VALVES MARKING

MARK	DESCRIPTION
A	TYPE NO.
B	YEAR OF MANUFACTURE
C	MATERIAL
D	SIZE
E	PRESSURE
F	CE. MARK
G	TEMPERATURE
H	TUV RHEINLAND / BERLIN-BRANDENBURG
HEAT NO. CAST ON THE BODY AND CAP MD LOGO CAST ON THE BODY OR ON THE NAMEPLATE	

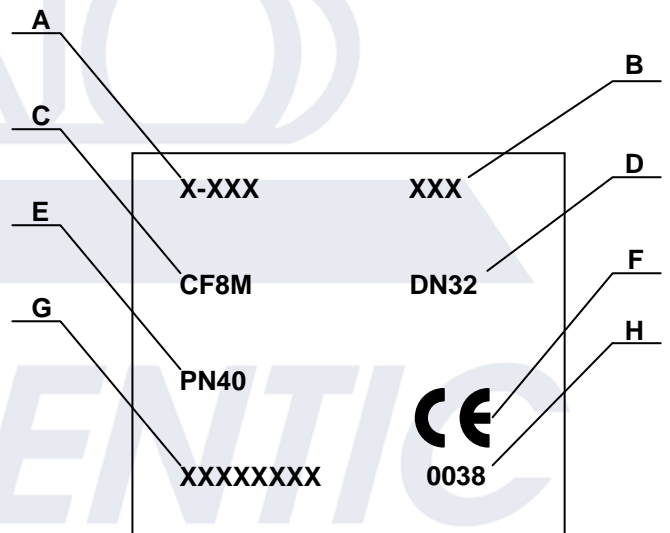

PED(SEP) VALVES MARKING UNDER DN25

MARK	DESCRIPTION
A	SIZE
B	MATERIAL
C	PRESSURE
HEAT NO. CAST ON THE BODY AND CAP MD LOGO CAST ON THE BODY OR ON THE NAMEPLATE	

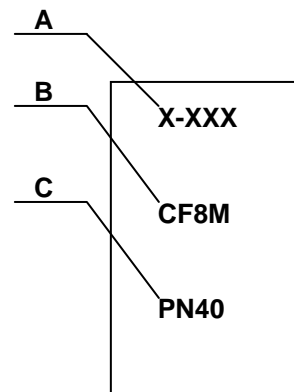

OUTSIDE THE EU COUNTRIES NON-PED VALVES MARKING

MARK	DESCRIPTION
A	SIZE
B	MATERIAL
C	PRESSURE
HEAT NO. CAST ON THE BODY AND CAP MD LOGO CAST ON THE BODY OR ON THE NAMEPLATE	

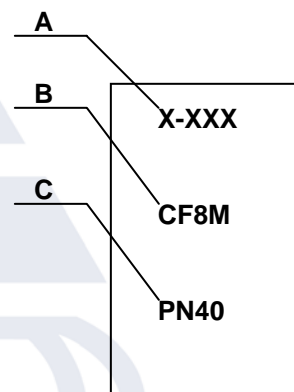

Limitation:

1. Valves are not to be used in safety functions such as safety loops or separating incompatible fluids.
2. In-line service only, not recommended for end of line service.
3. On-off service only (not to be used for throttling)
4. Do not use for slurries or fluids containing solids that can build up in valve cavities.
5. To provide an optimum service, the valve should be operated only in its fully open or fully closed position.
6. For a single acting actuator, a normal-open actuator will go back to open position when the pressure source is gone and vice versa.
7. For a double acting actuator, the actuator will stop at end position when the pressure source is gone.

Storage:

All valves are packed in strong cardboards (plastic bags for smaller sizes) to avoid any possible damage during transportation. If the items are not for immediate use, please follow the precautions:

1. Keep the valves in complete open position. Never leave the valve in the partially open position.
2. The valves should be appropriately protected and stored against dust, dirt, mud, wet and sea water.
3. Carbon steel valves have a "Black oxide" and the dipped finish. This nontoxic process is performed to retard rusting during storage. It is not a substitute for paint or other means of protective coating to be applied to the valve once installed. For stainless steel valves, as their natural finish, it is no need to have any additional protection once installed.

Installation:

1. Valve pressure varies under different valve series, sizes, application temperatures and the material of the main parts. Please verify the application within the limits and as described on the valve body or nameplate from Modentic.
2. Prior to the installation, check the valve as well as the connecting parts to make sure they are free from dirt and burrs. And it might be necessary to flush the valve, valve cavity and the pipes to remove the accumulated dirt and burrs.
3. Valves should be operated for at least two complete cycles before the installation to the pipe.
4. Keep the valve in full open position.
5. **Flanged Ends**
 - a. Check companion of flanges are dimensionally compatible with the flanges on the valve body and make sure sealing surfaces are free of grease, dirt etc.
 - b. Prepare the suitable gasket for flanges connection and put that between the connecting flanges.
 - c. Connect the flanges with the appropriate size bolts and heavy hex nuts which confirm to comparison standard.
 - d. Tight flange bolts as recommended by gasket manufacturer and standard.
 - e. Following installation, execute leak and operating tests.
6. **Threaded Ends**
 - a. Check specification of threads on mating pipe.
 - b. Apply joint compound to the male end of joint only.
 - a. Use suitable sealing material.
 - b. Use wrench and apply force on the hexagon end of the valve only. Apply force to other area of valve may seriously damage the valve.

c. Following installation, carry out leak and operating tests.

7. Socket Weld Ends

- a. For welded ends, make sure all the grease on the welded ends are removed.
- b. It should be tightly closed before welding or installation to prevent damage to the seating surfaces and stem caused by thermal expansion during the socket welding process.
- c. Prior to welding, ends caps must be removed to prevent seat or gasket from being damaged by the overheating while welding.
- d. Weld the end caps on the pipe stub. Be careful for the welded part, it may be super heat for minutes before completely cool down.
- e. Prior to assembly the body back to the end caps, clean both end caps carefully. Any particle left could damage the ball surface or the valve port which would lead to leakage.
- f. Tightened the body bolts evenly, check the valve for proper operation.
- g. Following installation, perform leak and operating tests.

9. To avoid the damage to the valve and the operator, don't measure the torque through the valve.

10. Install the valve in such a way that extensive stresses in any direction on the valve are avoided.

11. Always do leak test to the system before using.





► **Flow Patterns of Valve**

3+1 WAY BALL VALVE



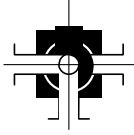
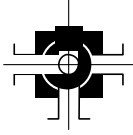

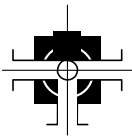

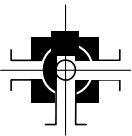

TURN PORT	0°	90°	180°	270°
L				
T				

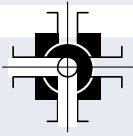
TURN PORT	0°	90°	180°	270°
DOUBLE-L				
DOUBLE-T				





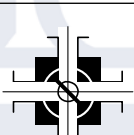
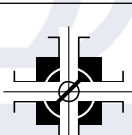

3 WAY BALL VALVE

TURN PORT	0°	90°	180°	270°
L				
T				

4 WAY BALL VALVE

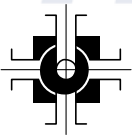
TURN PORT	0°	90°	180°	270°
L				
T				
X				

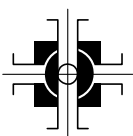
5 WAY BALL VALVE

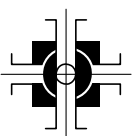
TURN PORT	0°	90°	180°	270°
L				
T				

TURN PORT	0°	90°	180°	270°
DOUBLE-L				
DOUBLE-T				

Maintenance:

1. Before making the maintenance, always advise the maintenance personnel that the proper eye, head and whole body protection always be utilized.
2. Before making the maintenance, always make sure the pressure is released safely by partly opening the valve.
3. Prior to the maintenance, flush the valves and the pipe lines attached and make sure that no (dangerous) residues are left. Ensure that the installation, together with pressure containing parts is depressurized and secured.
4. There is a possibility that a dangerous pressurized fluid or gas is trapped in the valve cavity, release this safely by partly opening the ball valve.
5. It is impossible to predict the frequency of the maintenance interval. The maintenance interval is dependant upon several factors which are not foreseeable by the manufacturer.
6. It is important to recognize stem and seat leakage and this is not to be left unattended.

User's note:

1. End-users has the responsibility to check the wall thickness in regular intervals due to wear/ tear/ corrosion of the fluid in order to ensure the wall thickness is not below the minimum safety thickness allowed in the standard.
2. The most important thing is to keep off the injury to the personal and the damage to the equipment.