

Ball Valve type 546 Pro

Ball Valve type 546 Pro, manually operated



Type 546 Pro
manually operated

Product description

The Ball Valve type 546 Pro is the ideal valve for use in applications ranging from simple water applications right up to demanding chemical processes. Its modular construction guarantees simple operation, flexibility, universal automation options and the greatest possible process safety.

Function

The ball valve uses a rotating ball with a hole through it that allows straight-through flow in the open position and shuts off flow when the ball is rotated 90°. This valve is mainly used for open/close functions, and for regulating applications.

Benefits/features

The Ball Valve type 546 Pro modular design always adapts the actual requirements. Whether electric, pneumatic or manual operation, including optional accessories, it flexibly meets all requirements.

- Lockable lever equipped as standard
- Manual valve or actuated valve with/without electrical position feedback
- Ergonomic hand lever with integrated tool to open the union bushing
- Labeling in lever (optional)
- Integrated fixation system with mounted threaded inserts as standard
- Spacers keep the line of the piping system and simplify installation
- Individual online configuration is possible
- Unique Data Matrix Code for traceability
- Oil-free and LABS-cleaned version
- Very high flow rate
- Universal interface makes a combination with all actuators possible
- Manual spring return unit (dead man lever)
- Relief well to avoid gas accumulation possible (e.g. for H₂O₂)
- Version with linear flow characteristic available due to special ball (opening angle scaled in 0 % - 100 % on index plate)

Applications

- Chemical process industry
- Water treatment
- Microelectronics
- Measurement and control
- Shipbuilding
- Food & beverage

Flow media

Neutral and aggressive media with a small amount of particles/solids. The chemical resistance is independent of the selected valve material ([see online tool ChemRes PLUS](#)).

Transport of compressed air

Ball valves type 546 Pro are suitable for compressed air regulation up to 10 bar (at 20 °C). The compressed air must be dry and free of oil. For this application PP-H is recommended as valve body material and FKM* for the gaskets.

Suitable piping systems are ecoFIT (PE) or INSTAFLEX (PB). The ball valve type 546 Pro is available with suitable connection parts.

*FKM is suitable for compressed air containing mineral oil. Some ester oils can attack the material FKM, in such cases the use of EPDM gaskets is recommended.

Technical data

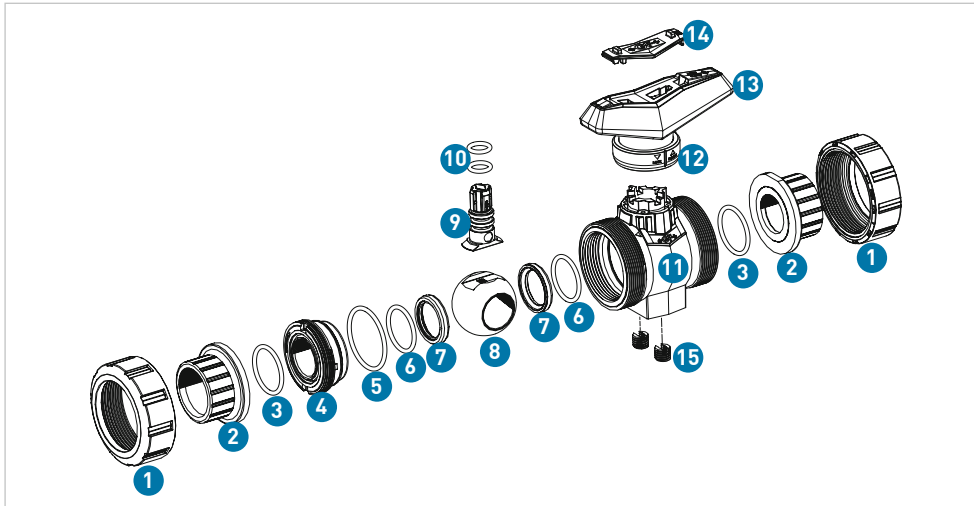

- 1 Union nut
- 2 Connecting part
- 3 Union seal
- 4 Union bush
- 5 Body seal
- 6 Backing seal
- 7 Ball seat
- 8 Ball
- 9 Stem
- 10 Stem seals
- 11 Body
- 12 Locking ring
- 13 Lever (lockable)
- 14 Lever clip
- 15 Threaded insert

Specification

Dimensions	d16/DN10 – d110/DN100 (d160/DN150), 3/8" – 4" (6")	
Materials	Valve body	PVC-U, PVC-C, ABS, PP-H, PVDF
	Lever	PP-GF30
Gasket materials	O-rings	EPDM, FKM, FFKM
	Ball seat	PTFE, PVDF
Pressure levels	ABS / PP-H	PN10
	PVC-U / PVC-C / PVDF	PN16
Connections	Fusion / solvent cement sockets	ISO, ASTM, JIS, BS
	Fusion / solvent cement spigot	ISO
	Threaded socket	Rp, NPT, Rc
	Backing flange	ISO, ANSI, BS, JIS
	Butt fusion spigots	SDR11 and SDR17.6
	PE100 electrofusion spigot or butt fusion spigot	SDR11 and SDR17.6
Actuation variants	Manually operated (lockable hand lever)	
	Pneumatic FC, FO, DA with and without manual override	
	Electrical AC: 100 – 230 V, AC/DC: 24 V, with / without manual override	
Flange standards	EN 1092 PN 10, ASME B16.5 Class 150, BS 1560-3.2 Class 150, JIS B2220 10K	
Third-party actuators	EN ISO 5211	
Marking	DataMatrix-Code with production data	
Product standard	EN ISO 16135	
Test standard	ISO 9393-2, EN 12266-1 (leakage rate A)	
Approvals	ACS, D.M. 174, DNV, FDA, QAP/ITP, NSF/ANSI, SIL, WRAS, ABS, BV, DiBT, RINA, LR	

Kv 100 values

DN (mm)	Inch (inch)	d (mm)	Type 546 Pro		
			Kv 100 (l/min)	Cv 100 (gal/min)	Kv 100 (m ³ /h)
10	3/8	16	70	4.9	4
15	1/2	20	185	12.9	11
20	3/4	25	350	24.5	21
25	1	32	700	49.0	42
32	1 1/4	40	1000	70.0	60
40	1 1/2	50	1600	112.0	96
50	2	63	3100	217.1	186
65	2 1/2	75	5000	350.0	300
80	3	90	7000	490.0	420
100	4	110	11000	770.0	660

Flow characteristics type 546 Pro

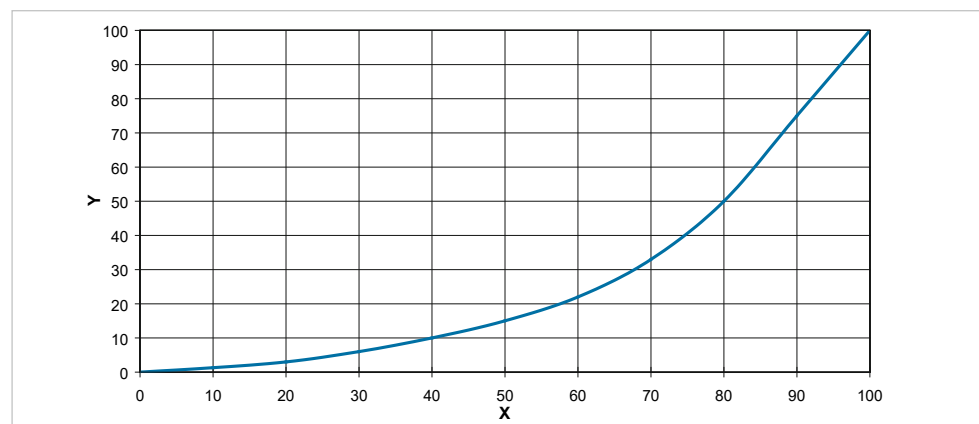

X Opening angle (%)
Y Kv, Cv value (%)

Pressure-temperature diagrams

The following pressure-temperature diagrams are based on a service life of 25 years and water or similar media.

T Temperature (°C, °F)

P Permissible pressure (bar, psi)

PVC-U

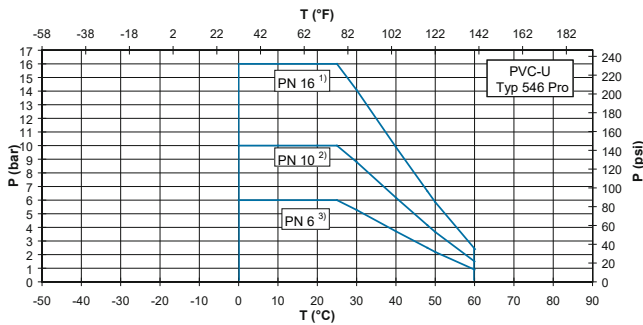

- 1) The central part of the ball valve is designed for the nominal pressure PN16
- 2) Depending on the connection, the nominal pressure is reduced to PN10
- 3) Depending on the connection, the nominal pressure is reduced to PN6

PVC-C

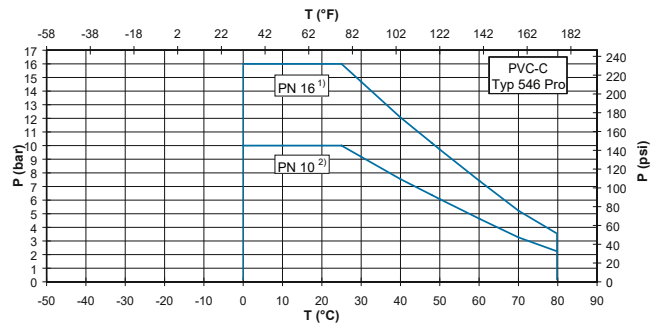

- 1) The central part of the ball valve is designed for the nominal pressure PN16
- 2) Depending on the connection, the nominal pressure is reduced to PN10

ABS

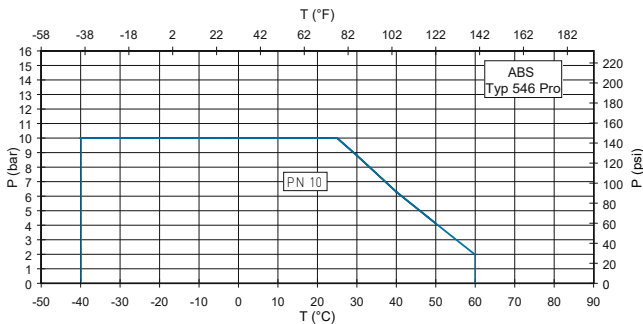

PP

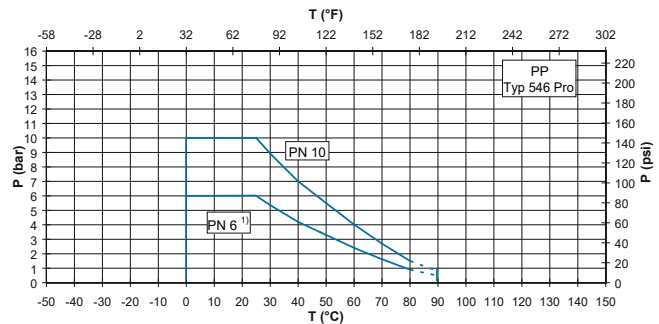

- 1) For example, ball valve with butt fusion spigot PP or PE100, SDR 17

PVDF

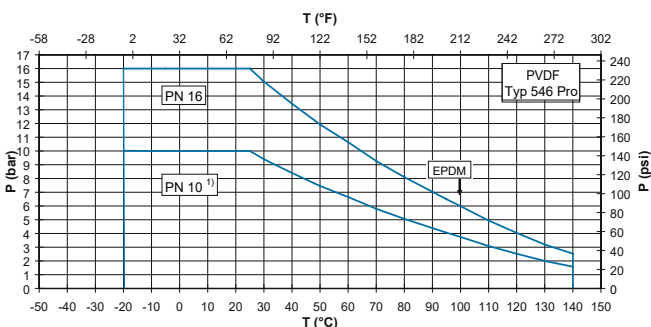

- 1) For example, ball valve with threaded socket EPDM gasket up to max. 100 °C

Pressure losses

d16/DN10 – d63/DN50

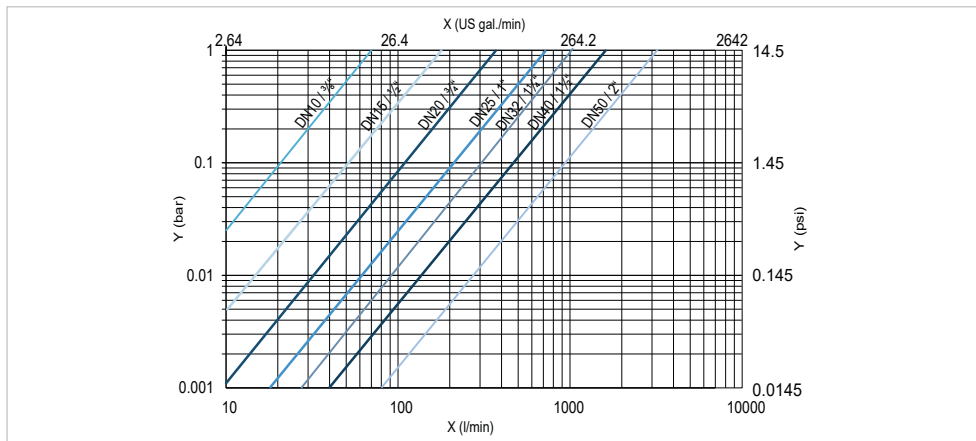

- X Flow rate (l/min, US gal/min)
- Y Pressure loss Δp (bar, psi)

d75/DN65 – DN100

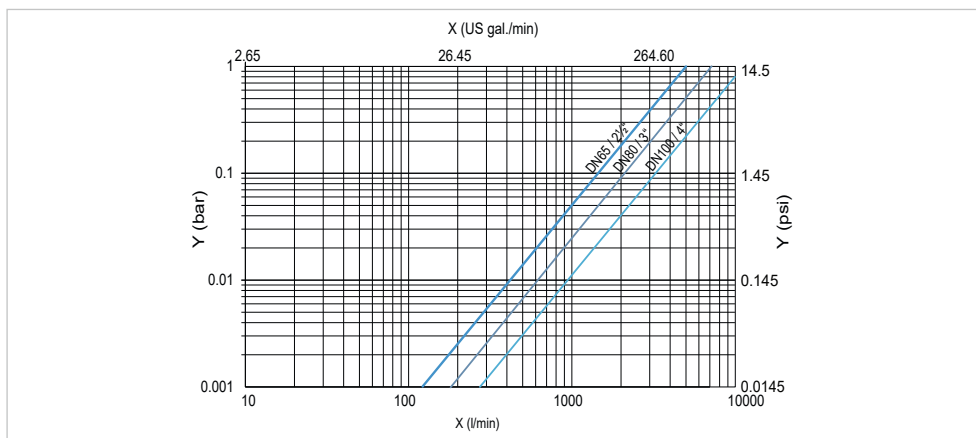

- X Flow rate (l/min, US gal/min)
- Y Pressure loss Δp (bar, psi)

Operating torque

DN10 – DN50

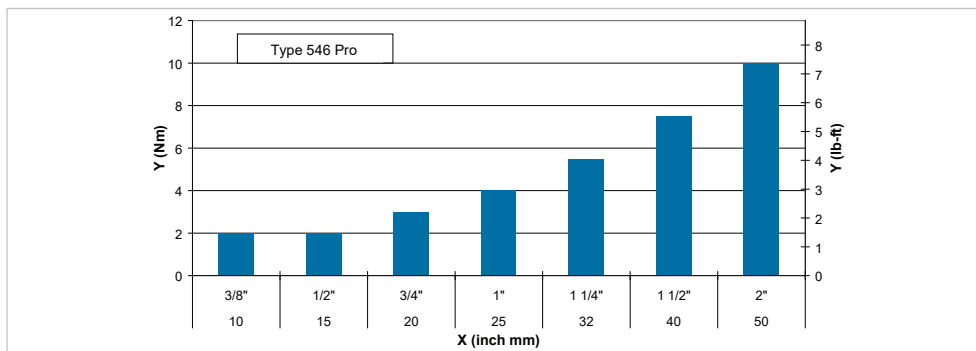

- X Nominal diameter DN (mm, inch)
 - Y Tightening torque (Nm, lb-ft)
- Average values at nominal pressure. Depending on the application (e.g. operating speed, fluid, temperature, etc.) about 2 times the operating torque should be taken for sizing actuators.

DN65 – DN100

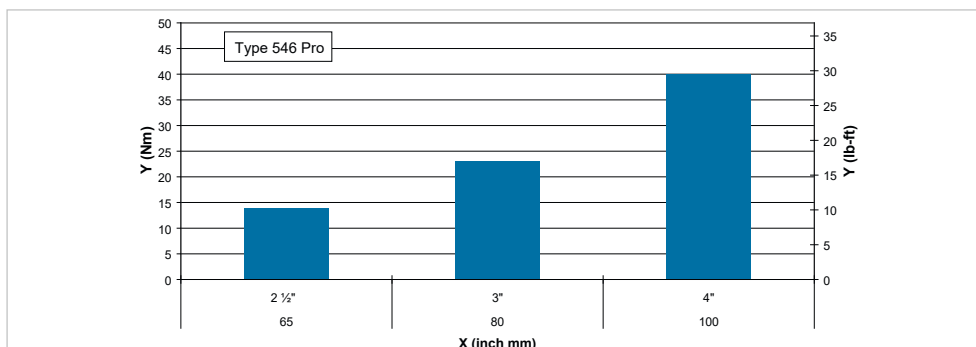

- X Nominal diameter DN (mm, inch)
 - Y Tightening torque (Nm, lb-ft)
- Average values at nominal pressure. Depending on the application (e.g. operating speed, fluid, temperature, etc.) about 2 times the operating torque should be taken for sizing actuators.

Reference values for tightening torque of screws

Flange connections with profile flange seal or flat gaskets

d (mm)	DN (mm)	Inch (inch)	Total number of screws (for 2 flange connections) standard nut ¹⁾	Torque (Reference values) Profile flange gasket ²⁾		Torque (Reference values) Flat gasket	
				(Nm)	(lb-ft)	(Nm)	(lb-ft)
20	15	½	8 x M12 x 50	10	7.4	10	7.4
25	20	¾	8 x M12 x 55	10	7.4	10	7.4
32	25	1	8 x M12 x 60	10	7.4	15	11
40	32	1 ¼	8 x M16 x 70	15	11	20	15
50	40	1 ½	8 x M16 x 70	15	11	25	18
63	50	2	8 x M16 x 80	20	15	35	26
75	65	2 ½	8 x M16 x 90	25	18	50	37
90	80	3	16 x M16 x 100	15	11	30	22
110	100	4	16 x M20 x 130	20	15	35	26

¹⁾ For Type 546 Pro connecting parts made of PP in combination with backing flanges, use half of the standard nut height

²⁾ Preferred gasket Type (suited for plastics)

Technical basics

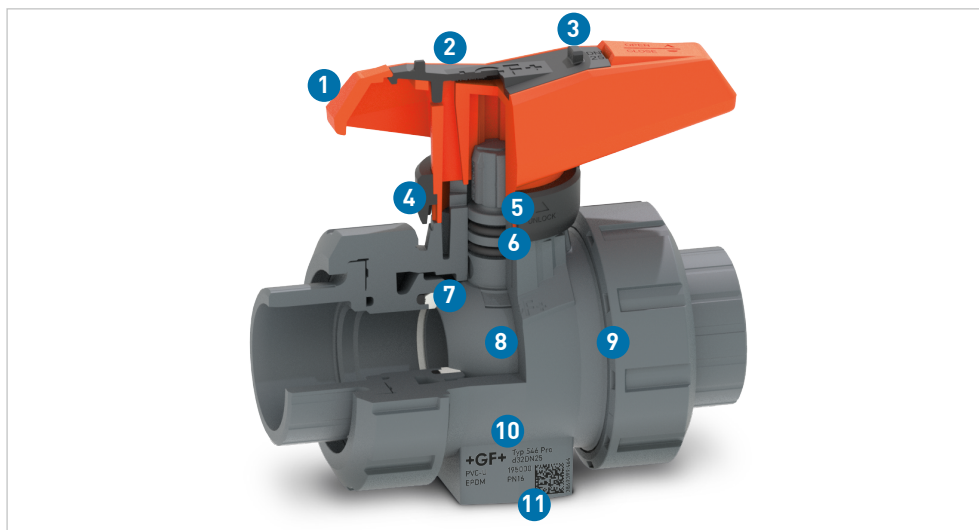

- 1 Ergonomic lever, lockable as standard
- 2 Quick-label on request
- 3 Integrated union bush tool
- 4 Interface for flexible automation and accessories
- 5 Reinforced security break point in the stem interface
- 6 Double stem seals
- 7 Dynamic backing seal
- 8 Smooth spherical surface
- 9 Saw tooth thread suitable for plastics
- 10 Fastening system with integrated threaded bushes
- 11 Data-Matrix-Code

With the backing seals, the ball has a floating position. This results in preloading and hence a constant seal. Stem, backing, housing and connection seals are made of EPDM or FKM.

The stems with predefined break point above the upper O-ring help prevent leaks to the outside in case of damage for manual valves. The new designed security break point in the interface allows the user to replace the coupling piece within a few minutes and without interruption if an automated valve is subject to wear.

i All ball valves in DN10 – 100 are available as radially removable valves with two threaded connections according to EN ISO 16135.

Union bushing

The design of the hand lever serves as a tool for installing the union bushings. The union bushing has a reverse thread in order to avoid unintentional opening when removing the coupling nuts or the thread connections.

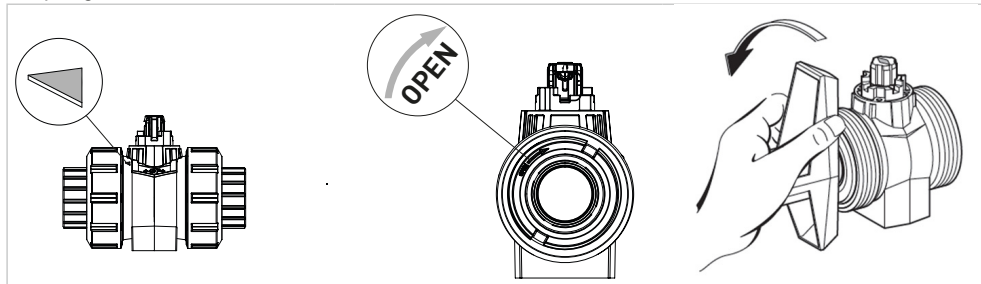

Locking function

Move the ball valve to the desired open or closed position and press down the locking ring. Attach lock to eye to protect lever from unauthorized actuation.

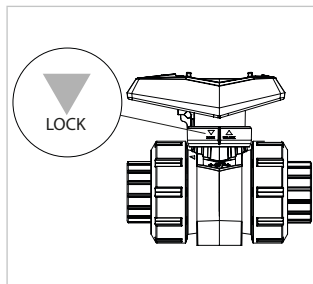

Valve handling

Removing the lever

When removing the lever, the locking ring must be in the open position (top).

Installation notes

When installing the ball valve, ensure that it is always installed into the system in an opened ball position.

Selection of lubricant

All seals should be lubricated with a silicone-based grease. Using the wrong lubricants can damage the material of the ball valve or seals.

- Mineral oil-based and Vaseline (petrolatum) are not appropriate.
- For silicone-free ball valves, please consult the special manufacturer's instructions.

Maintenance notes

Ball valves require no maintenance under normal operating conditions (clear water). However, the following measures must be considered:

- Regularly check that no medium escapes to the outside.
- We recommend a function test for ball type valves that are kept permanently in the same position 1 – 2 times per year to check functionality.

 Installation and maintenance must be performed according to the corresponding installation instructions. The installation manual is included with the product, see also the online product catalogue at www.gfps.com

Design type 546 Pro with linear flow characteristics

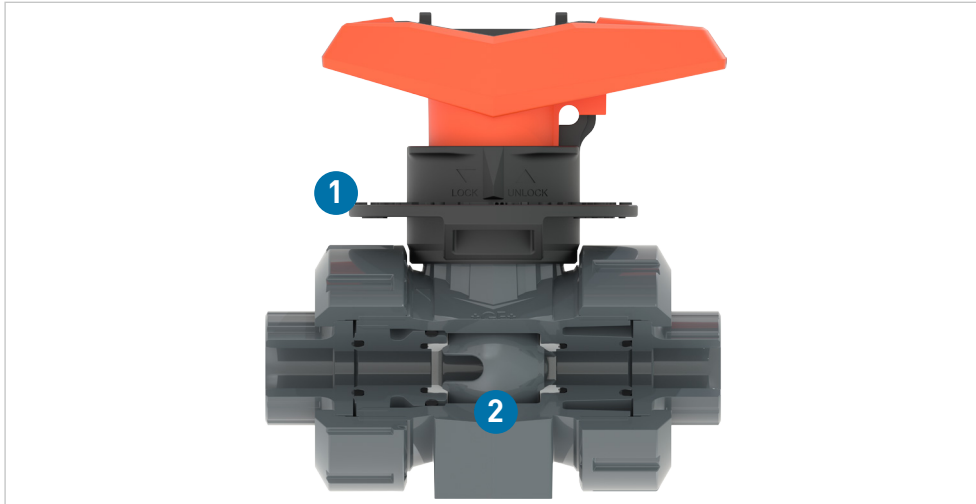

- 1 Ball with linear flow characteristic
- 2 Special index plate with opening angle in °

Dimensions

Ball Valve type 546 Pro with solvent cement spigots or socket fusion spigots, metric

d (mm)	DN (mm)	D (mm)	H (mm)	H1 (mm)	H2 (mm)	L (mm)	L1 (mm)	L2 (mm)	L4 (mm)	L5 (mm)	L6 (mm)	M
16	10	50	54	27	12	114	72	56	25	26	46	M6
20	15	50	54	27	12	124	72	56	25	26	46	M6
25	20	58	66	30	12	144	93	65	25	34	59	M6
32	25	68	71	36	12	155	93	71	25	34	59	M6
40	32	84	85	44	15	175	110	85	45	41	69	M8
50	40	97	92	51	15	193	110	89	45	41	69	M8
63	50	124	108	64	15	224	128	101	45	49	79	M8
75	65	166	149	85	15	284	270	136	70	64	206	M8
90	80	200	161	105	15	300	270	141	70	64	206	M8
110	100	238	178	123	22	340	320	164	120	64	256	M12

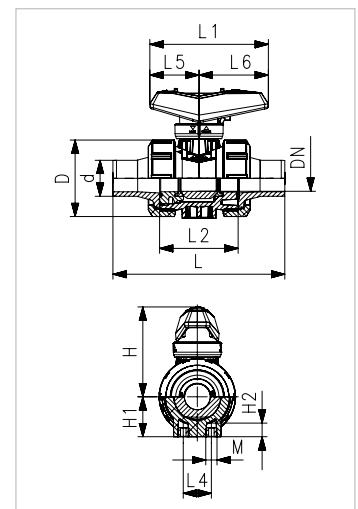

Ball Valve type 546 Pro with solvent cement sockets, fusion sockets or threaded sockets, metric

d (mm)	DN (mm)	D (mm)	H (mm)	H1 (mm)	H2 (mm)	L (mm)	L1 (mm)	L2 (mm)	L4 (mm)	L5 (mm)	L6 (mm)	z (mm)	M
16	10	50	54	27	12	92	72	56	25	26	46	68	M6
20	15	50	54	27	12	95	72	56	25	26	46	67	M6
25	20	58	66	30	12	110	93	65	25	34	59	76	M6
32	25	68	71	36	12	124	93	71	25	34	59	82	M6
40	32	84	85	44	15	147	110	85	45	41	69	98	M8
50	40	97	92	51	15	157	110	89	45	41	69	99	M8
63	50	124	108	64	15	184	128	101	45	49	79	111	M8
75	65	166	149	85	15	233	270	136	70	64	206	148	M8
90	80	200	161	105	15	254	270	141	70	64	206	156	M8
110	100	238	178	123	22	301	320	164	120	64	256	178	M12

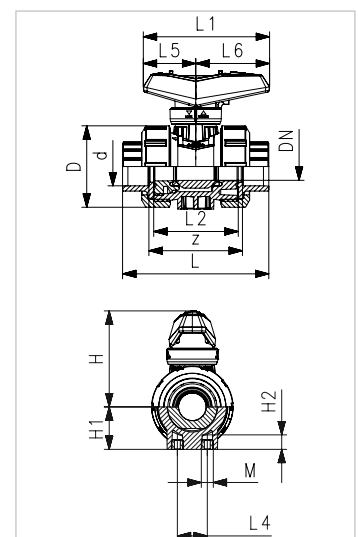

Ball Valve type 546 Pro with solvent cement sockets RP, fusion sockets RP or threaded sockets Rp

Rp	DN	D	H	H1	H2	L	L1	L2	L4	L5	L6	z	M
inch	(mm)	(mm)	(mm)	(mm)	(mm)	(mm)	(mm)	(mm)	(mm)	(mm)	(mm)	(mm)	
3/8	10	50	54	27	12	92	72	56	25	26	46	64	M6
1/2	15	50	54	27	12	95	72	56	25	26	46	63	M6
3/4	20	58	66	30	12	110	93	65	25	34	59	73	M6
1	25	68	71	36	12	124	93	71	25	34	59	79	M6
1 1/4	32	84	85	44	15	147	110	85	45	41	69	94	M8
1 1/2	40	97	92	51	15	157	110	89	45	41	69	95	M8
2	50	124	108	64	15	184	128	101	45	49	79	108	M8
2 1/2	65	166	149	85	15	233	270	136	70	64	206	144	M8
3	80	200	161	105	15	254	270	141	70	64	206	151	M8
4	100	238	178	123	22	301	320	164	120	64	256	174	M12

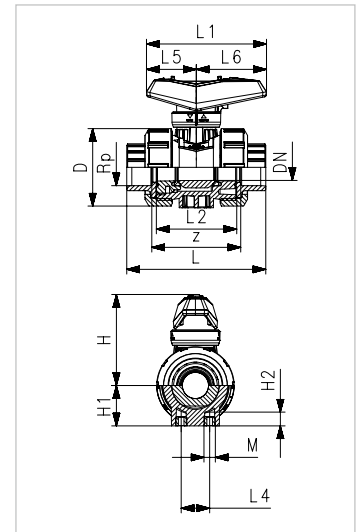

Ball Valve type 546 Pro with solvent cement sockets NPT, fusion sockets NPT or threaded sockets NPT

Rp	DN	D	H	H1	H2	L	L1	L2	L4	L5	L6	z	M
inch	(mm)	(mm)	(mm)	(mm)	(mm)	(mm)	(mm)	(mm)	(mm)	(mm)	(mm)	(mm)	
3/8	10	50	54	27	12	92	72	56	25	26	46	64	M6
1/2	15	50	54	27	12	95	72	56	25	26	46	63	M6
3/4	20	58	66	30	12	110	93	65	25	34	59	73	M6
1	25	68	71	36	12	124	93	71	25	34	59	79	M6
1 1/4	32	84	85	44	15	147	110	85	45	41	69	94	M8
1 1/2	40	97	92	51	15	157	110	89	45	41	69	95	M8
2	50	124	108	64	15	184	128	101	45	49	79	108	M8
2 1/2	65	166	149	85	15	233	270	136	70	64	206	144	M8
3	80	200	161	105	15	254	270	141	70	64	206	151	M8
4	100	238	178	123	22	301	320	164	120	64	256	174	M12

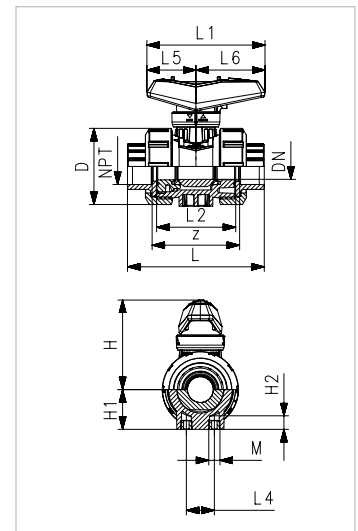

Ball Valve type 546 Pro with fixed flanges serrated, metric

d	DN	D	D1	D3	H	H1	H2	L	L1	L2	L3	L4	L5	L6	M
(mm)	(mm)	(mm)	(mm)	(mm)	(mm)	(mm)	(mm)	(mm)	(mm)	(mm)	(mm)	(mm)	(mm)	(mm)	
20	15	94	65	14	87	27	12	120	82	56	130	25	35	47	M6
25	20	103	75	14	104	30	12	139	105	65	149	25	44	62	M6
32	25	115	85	14	115	36	12	150	105	71	160	25	44	62	M6
40	32	138	100	18	139	44	15	170	131	85	180	45	57	74	M8
50	40	147	110	18	152	51	15	189	131	89	197	45	57	74	M8
63	50	162	125	18	181	64	15	220	152	101	228	45	66	86	M8

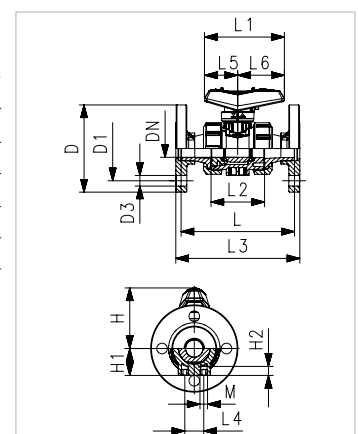

Ball Valve type 546 Pro with backing flanges, metric

d (mm)	DN (mm)	D (mm)	D1 (mm)	D3 (mm)	H (mm)	H1 (mm)	H2 (mm)	L1 (mm)	L2 (mm)	L3 (mm)	L4 (mm)	L5 (mm)	L6 (mm)	M (mm)
20	15	96	70	15	87	27	12	82	56	143	25	35	47	M6
25	20	101	75	15	104	30	12	105	65	171	25	44	62	M6
32	25	126	90	19	115	36	12	105	71	187	25	44	62	M6
40	32	135	100	19	139	44	15	131	85	190	45	57	74	M8
50	40	140	105	19	152	51	15	131	89	212	45	57	74	M8
63	50	156	120	19	181	64	15	152	101	234	45	66	86	M8
75	65	176	140	19	150	85	15	269	136	290	70	64	206	M8
90	80	186	150	19	161	105	15	269	141	310	70	64	206	M8
110	100	220	180	18	178	123	22	319	164	350	120	64	256	M12

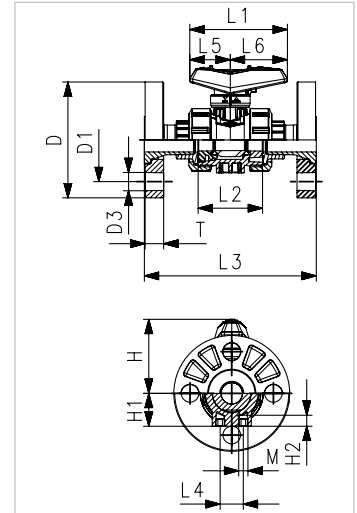

Ball Valve type 546 Pro with butt fusion spigots short, metric

d (mm)	DN (mm)	D (mm)	H (mm)	H1 (mm)	H2 (mm)	L (mm)	L1 (mm)	L2 (mm)	L4 (mm)	L5 (mm)	L6 (mm)	M (mm)	e (mm)
20	15	50	54	27	12	130	72	56	25	26	46	M6	1.9
25	20	58	66	30	12	144	93	65	25	34	59	M6	2.3
32	25	68	71	36	12	151	93	71	25	34	59	M6	2.9
40	32	84	85	44	15	171	110	85	45	41	69	M8	3.7
50	40	97	92	51	15	190	110	89	45	41	69	M8	4.6
63	50	124	108	64	15	221	128	101	45	49	79	M8	5.8

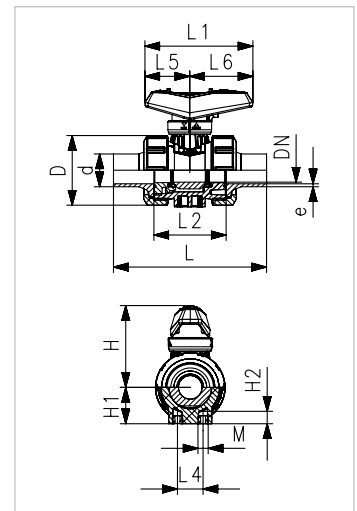

Ball Valve type 546 Pro with butt fusion spigots long, metric

d (mm)	DN (mm)	D (mm)	H (mm)	H1 (mm)	H2 (mm)	L (mm)	L1 (mm)	L2 (mm)	L4 (mm)	L5 (mm)	L6 (mm)	M (mm)	e (mm)
20	15	50	54	27	12	193	72	56	25	26	46	M6	1.9
25	20	58	66	30	12	218	93	65	25	34	59	M6	2.3
32	25	68	71	36	12	224	93	71	25	34	59	M6	2.9
40	32	84	85	44	15	250	110	85	45	41	69	M8	3.7
50	40	97	92	51	15	271	110	89	45	41	69	M8	4.6
63	50	124	108	64	15	321	128	101	45	49	79	M8	5.8

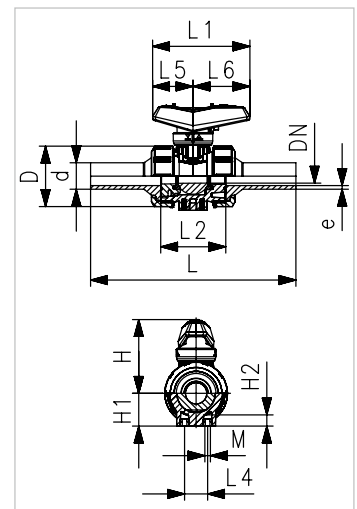

Accessories

Double sensor for electrical position feedback

After being mounted in the valve or in the interface module, the double sensor is used to signal the CLOSED or OPEN position of the valve via an electric signal to a controller, supplied by the customer. The switching states are also output optically via two integrated LEDs.

LED signal color	Function	Code
Closed: Green / Open: Red	PNP	198546001
Closed: Red / Open: Green	PNP	198546002
Closed: Green / Open: Red	NPN	198546005
Closed: Red / Open: Green	NPN	198546006
Closed: Green / Open: Red	NAMUR	198546003
Closed: Red / Open: Green	NAMUR	198546004



Suitable connection cables available as accessories

Spring reset unit, manual actuation (dead man's switch)

The spring reset unit (dead man's switch) is installed onto the ball valve type 546 Pro or type 543 Pro and ensures that the ball valve is closed automatically as soon as the handle is released. It is opened against the spring force.

DN (mm)	Code
DN10/15	198546082
DN20/25	198546083



Interface module, manual actuated

With the manually actuated interface module the open or closed position of the ball valve type 546 Pro or type 543 Pro can be transmitted via an electric signal to a customer control.

DN (mm)	Code	DN10-50	DN65-100
DN10/15	198546102		
DN20/25	198546103		
DN32/40	198546105		
DN50	198546107		
DN65/80	198546108		
DN100	198546109		

Interface module, automatic actuated

With the help of the automatically actuated interface module, electric or pneumatic actuators can be attached on the ball valve type 546 Pro or type 543 Pro, which allows the automation of the ball valve's change of position. In addition, an interface is available for the installation of an electrical position feedback indicator.

DN (mm)	Code Pneumatic GF actuator s PPA	Code Electric GF actuators EA/dEA
DN10/15	198546162	198546142
DN20	198546163	198546143
DN25	198546164	198546144
DN32	198546135	198546145
DN40	198546136	198546146
DN50	198546137	198546147
DN65/80	PPA40 198546165 PPA80 198546166	198546148
DN100	198546167	198546149

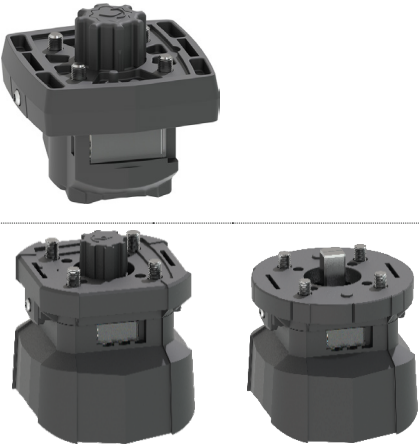

DN (mm)	SW	Code Norm actuators according to ISO 5211	DN10-50	DN65-100
DN10/15	SW09	198546122		
DN10/15	SW11/14	198546123		
DN20/25	SW09	198546124		
DN20/25	SW11/14	198546125		
DN32-40	SW11/14	198546126		
DN50	SW11/14	198546127		
DN65/80	SW11	198546128		
DN100	SW14	198546129		

Transparent lever clip

Type 546 Pro or type 543 Pro ball valves can be quickly and easily labelled with the most important information. Operation and maintenance can thus be made safer, faster and clearer. In addition, there are various standards which prescribe a clear marking of the pipeline.

DN (mm)	Pcs.	Code
DN10/15	10 Stk.	198807221
DN20/25	10 Stk.	198807222
DN32/40	5 Stk.	198807223
DN50	5 Stk.	198807224
DN65/80	5 Stk.	198807225
DN100	5 Stk.	198807226



Printed sheets for ball valve lever

Dimension	Code	Quantity	Picture
DN10/15	198 807 231	25 sheets with 48 labels each	
DN10/15	198 807 241	100 sheets with 48 labels each	
DN20/25	198 807 232	25 sheets with 24 labels each	
DN20/25	198 807 242	100 sheets with 24 labels each	
DN32/40	198 807 233	25 sheets with 18 labels each	
DN32/40	198 807 243	100 sheets with 18 labels each	
DN50	198 807 234	25 sheets with 11 labels each	
DN50	198 807 244	100 sheets with 11 labels each	
DN65/80	198 807 235	25 sheets with 6 labels each	
DN100	198 807 236	25 sheets with 4 labels each	

Printed sheets for interface modules

The transparent labeling clips are supplied with the interface modules.

The labeling can be used with hand operated valves with a manual interface as well as with automatically powered ball valves.

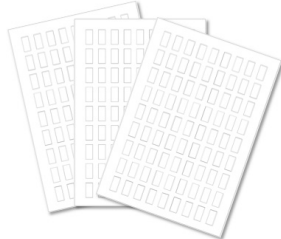
Dimension	Code	Quantity	Picture
DN10 - DN100	198 807 230	25 sheets with 81 labels each	

Further accessories

- Hand lever extension
- Adapter for padlocks
- Tool for disassembling interface modules
- Additional limit switches



For further information on accessories, refer to the online product catalogue at www.gfps.com

- Mobile apps and online tools to support configuration and calculation at www.gfps.com/tools



Ball Valve type 546 Pro, electric actuated (Type 127, 179–184)



Type 127
With electric actuator EA15

Type 179 – 184
With electric actuators EA and dEA

Product description

Type 127

The type 127 is designed for automated standard applications with no special demands. The Ball Valve type 127 is based on the Ball Valve type 546 Pro and the electric actuator EA15.

Type 179 – 184

The 179 – 184 series is designed as modular adjustable ball valves for applications which demand special process requirements. Ball valves are based on the Ball Valve type 546 Pro and the electric actuators EA or the smart electric actuator dEA.

Applications

- Chemical process industry
- Water treatment
- Microelectronics
- Measurement and control
- Ship building
- Food & beverage

Benefits/features

Type 127

- Electrical feedback with additional limit switches of different designs integrated into the actuator or interface module
- Integrated emergency manual override
- Optional: Fail-safe return unit with or without integrated battery pack

Type 179 – 184

- Electrical feedback with additional limit switches of different designs integrated into the actuator or in the interface module (optional 4-20 mA with Positioner)
- Rotation angle up to 355°; Preset to 0°-90°
- Up to 3 freely selectable stop positions (open/middle/close)
- Integrated emergency manual override
- Optional: Fail-safe return unit with or without integrated battery pack
- Optional: Cycle time monitoring
- Optional: Cycle counter
- Optional: Cycle time extension
- Optional: Motor current monitoring
- Optional: Positioner

Flow media

Neutral and aggressive media with a small amount of particles/solids. The chemical resistance is independent of the selected valve material ([see online tool ChemRes PLUS](#)).

Technical Data

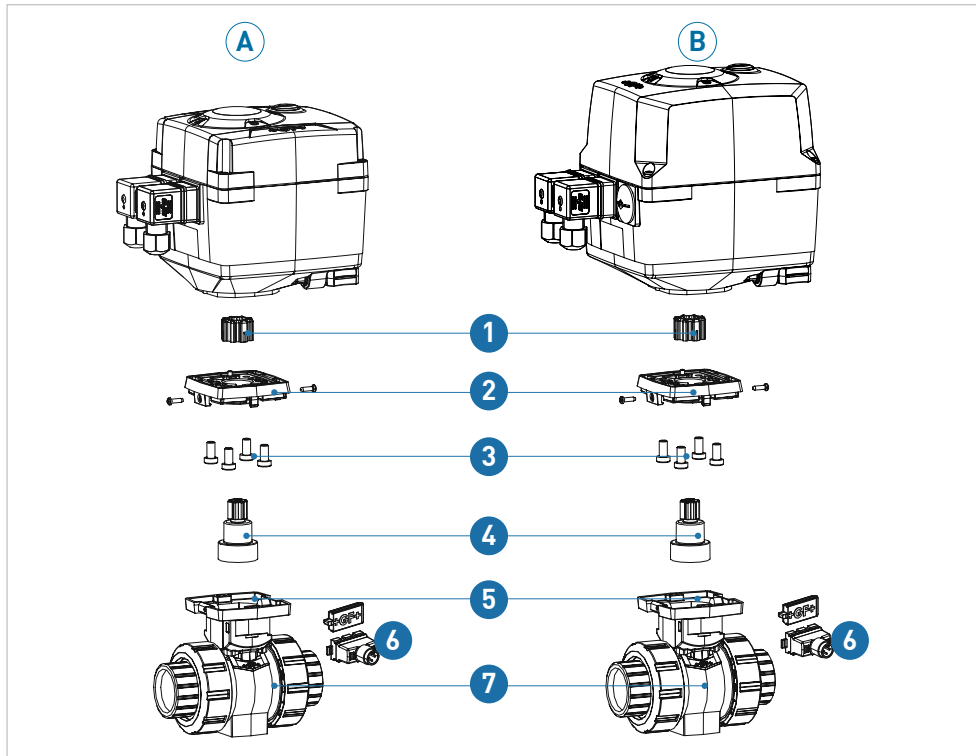

- A Actuator Type EA15
- B Actuator Type EA25/EA45/EA120
- 1 Adapter
- 2 Adapter plate
- 3 PT screws
- 4 Coupling piece
- 5 Interface housing
- 6 Labelling clip or double sensor for electrical position feedback (custom versions only)
- 7 Ball Valve Type 546 Pro

Specification

Dimensions	Type 127	EA15	d16/DN10 – d63/DN50
	Type 179-184	EA25	d16/DN10 – d63/DN50
		EA45	d75/DN65
		EA120	d90/DN80 – d110/DN100
Base type	Type 546 Pro		
Materials	Type 127, 179-184	PVC-U, PVC-C, ABS, PP-H, PVDF	
Seal materials		EPDM, FKM, FFKM, NBR	
Pressure levels		PN10	
Connections		Socket, spigot, flanges, threaded socket	
Connection standards	ISO, BS, ASTM, JIS		



The following technical data can be found in the Planning Fundamentals under "Ball Valve type 546 Pro, manually operated":

- Pressure-temperature diagram
- Pressure loss
- Flow characteristics
- Kv values
- Reference values for fastening screws

Technical basics

Differences between types 127 and 179 – 184

	Type 127	Type 179	Type 180	Type 181	Type 182	Type 183	Type 184
PVC-U	x	x			x	x	x
PVC-C	x	x			x		x
ABS	x	x				x	
PP-H	x		x				x
PVDF				x			x
ISO	x	x	x	x			
ASTM	x		x	x	x		
BS	x					x	
JIS	x						x

- The actuators are manufactured according to the specification of EN 61010-1, EC 89/336/EEC-EMV 73/23/EEC, LVD.
- All actuators have the CE marking.
- The actuator housings are made of PPGF (fiberglass-reinforced polypropylene) and external, stainless steel screws with low flammability.
- All electric actuators have an emergency manual override and an optical position indicator.

Properties of electric actuators

Actuator	Cycle time	Nominal torque	Actuating cycles at 20 °C	Duty cycle at 25 °C/15min
EA15	5s/90°	10Nm	150 000	40%
EA25 / dEA25	5s/90°	10 Nm	250 000	100%
EA45 / dEA45	6s /90°	20 Nm	100 000	50%
EA120 / dEA120	15s/90°	60 Nm	100 000	50%
EA250 / dEA250	20s/90°	100 Nm	75 000	35%

i All electric actuators have an IP67 rating in accordance with EN 60529 (with vertical installation and appropriate cable connection).

Valve handling

Installation notes

During installation, ensure that the actuator is correctly built onto and connected to the correct valve. In order to guarantee control provided on the customer side, the following points must be observed:

- Actuate valves with 90° rotary movement.
- Indicate the previously calibrated end positions of the valve via an electrical signal to the aforementioned system control.
- If the supply voltage fails, the actuator should remain in its current position. For this purpose, the installation of the manual override or the position reset unit is recommended (see accessories).

In case of interruption in the supply voltage, ensure that the actuator remains in the current position. For this, installation of an emergency manual override or reset unit is recommended (refer to "Accessories").

Maintenance notes

Set maintenance intervals as per the conditions of use (e.g., actuating cycles, medium, ambient temperature). As part of the regular system inspection, carry out the following maintenance activities:

- Regularly check that no medium escapes to the outside.
- We recommend a function test for ball type valves that are kept permanently in the same position 1 – 2 times per year to check functionality.
- Check that cover of the emergency manual override is correctly fitted. If necessary, fit cover.
- Check that housing cover of the actuator is fitted with 4 screws. Insert screws if necessary.
- Check if grating noises are coming from the actuator. Replace actuator, see assembly instructions for building valve with actuator.
- Check that position display matches signal of the control. If necessary, adjust limit switches.

For frequent control operations or due to chemical attack on the sealing material, it may become necessary to replace parts inside the valve.



Installation and maintenance must be performed according to the corresponding installation instructions. The installation manual is included with the product, see also the online product catalog at www.gfps.com

Dimensions

Type 127 solvent cement sockets

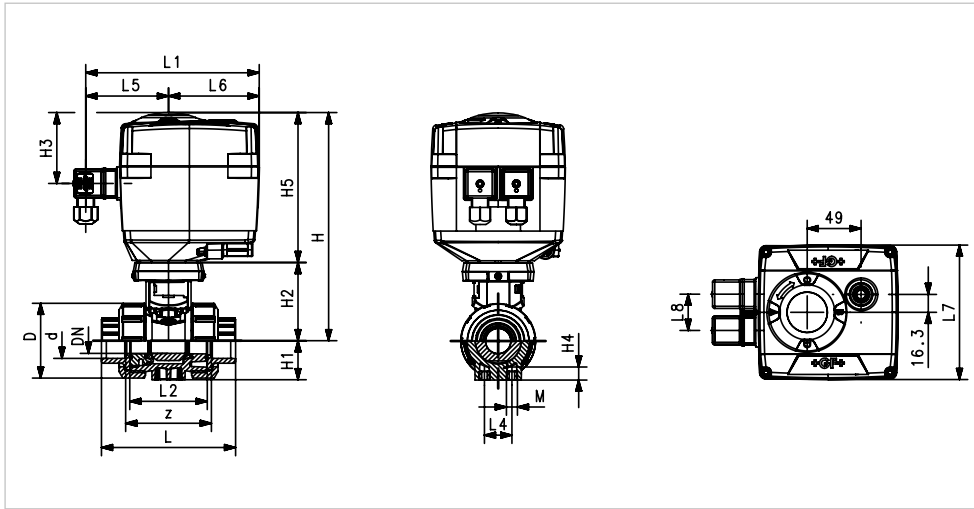

d (mm)	DN (mm)	D (mm)	H (mm)	H1 (mm)	H2 (mm)	H3 (mm)	H5 (mm)
16	10	50	200	27	64	64	137
20	15	50	200	27	64	64	137
25	20	58	209	30	73	64	137
32	25	68	209	36	73	64	137
40	32	84	220	44	84	64	137
50	40	97	220	51	84	64	137
63	50	124	243	64	106	64	137

L (mm)	L1 (mm)	L2 (mm)	L4 (mm)	L5 (mm)	L6 (mm)	L7 (mm)	L8 (mm)	z (mm)
92	161	56	25	77	83	122	33	64
95	161	56	25	77	83	122	33	64
110	161	65	25	77	83	122	33	72
123	161	71	25	77	83	122	33	79
146	161	85	45	77	83	122	33	94
157	161	89	45	77	83	122	33	95
183	161	101	45	77	83	122	33	107

Type 127 Solvent cement spigots

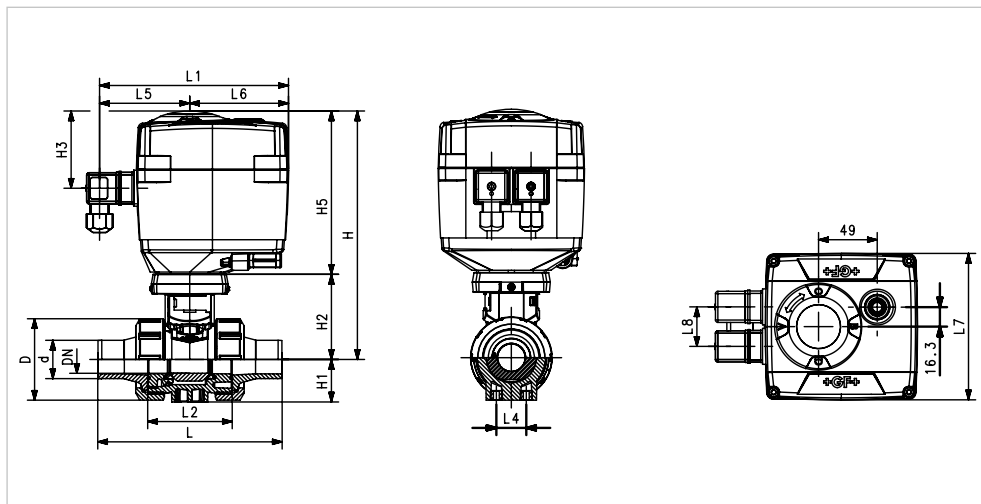

d (mm)	DN (mm)	D (mm)	H (mm)	H1 (mm)	H2 (mm)	H3 (mm)	H5 (mm)
16	10	50	200	27	64	64	137
20	15	50	200	27	64	64	137
25	20	58	209	30	73	64	137
32	25	68	209	36	73	64	137
40	32	84	220	44	84	64	137
50	40	97	220	51	84	64	137
63	50	124	243	64	106	64	137

L (mm)	L1 (mm)	L2 (mm)	L3 (mm)	L4 (mm)	L5 (mm)	L6 (mm)	L7 (mm)	L8 (mm)
114	161	56	130	25	77	83	122	33
124	161	56	130	25	77	83	122	33
144	161	65	150	25	77	83	122	33
154	161	71	160	25	77	83	122	33
174	161	85	180	45	77	83	122	33
194	161	89	200	45	77	83	122	33
224	161	101	230	45	77	83	122	33

Type 127 threaded sockets Rp

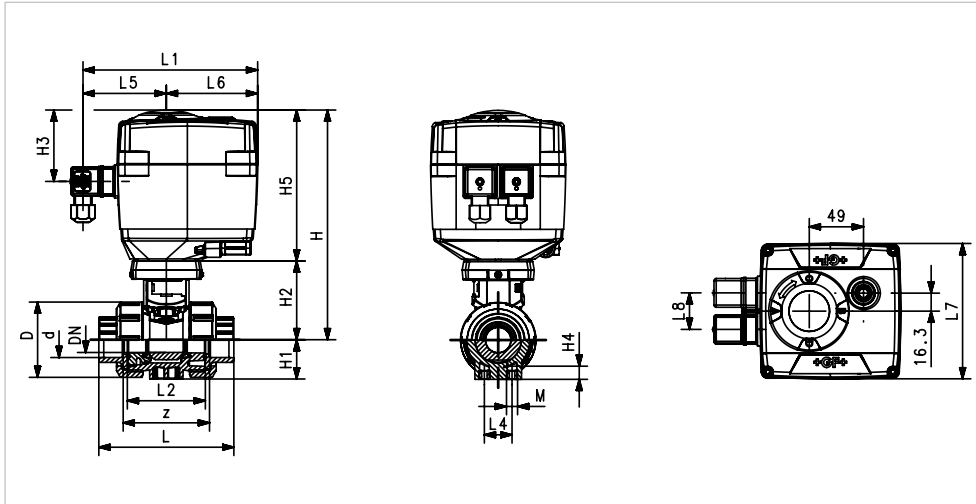

Rp (inch)	DN (mm)	D (mm)	H (mm)	H1 (mm)	H2 (mm)	H3 (mm)	H5 (mm)
3/8	10	50	200	27	64	64	137
1/2	15	50	200	27	64	64	137
3/4	20	58	209	30	73	64	137
1	25	68	209	36	73	64	137
1 1/4	32	84	220	44	84	64	137
1 1/2	40	97	220	51	84	64	137
2	50	124	243	64	106	64	137

L (mm)	L1 (mm)	L2 (mm)	L4 (mm)	L5 (mm)	L6 (mm)	L7 (mm)	L8 (mm)	z (mm)
92	161	56	25	77	83	122	33	64
95	161	56	25	77	83	122	33	64
110	161	65	25	77	83	122	33	72
123	161	71	25	77	83	122	33	79
146	161	85	45	77	83	122	33	94
157	161	89	45	77	83	122	33	95
183	161	101	45	77	83	122	33	107

Type 127 fixed flange serrated, metric

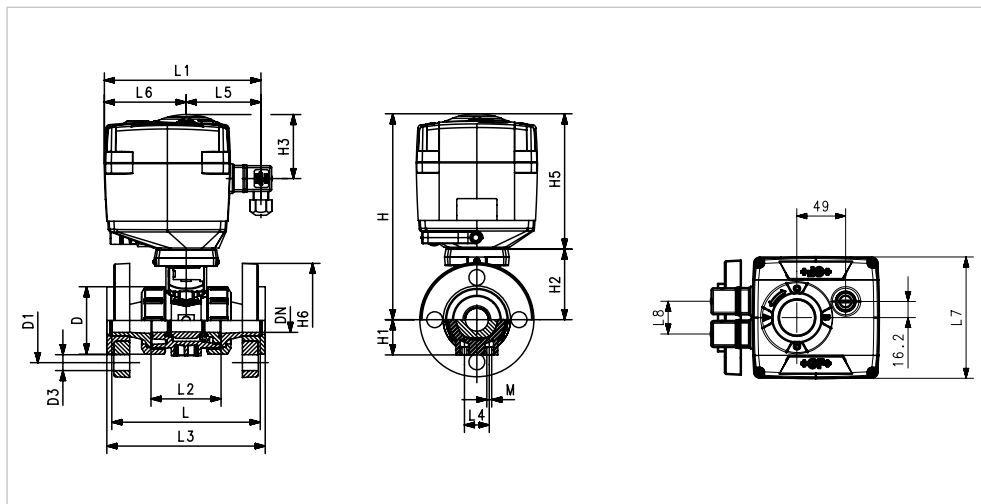

d (mm)	DN (mm)	D (mm)	H (mm)	H1 (mm)	H2 (mm)	H3 (mm)	H5 (mm)	H6 (mm)
20	15	50	201	27	64	65	138	48
25	20	58	210	30	73	65	138	53
32	25	68	210	36	73	65	138	58
40	32	84	221	44	84	65	138	70
50	40	97	221	51	84	65	138	75
63	50	124	244	64	106	65	138	83

L (mm)	L1 (mm)	L2 (mm)	L3 (mm)	L4 (mm)	L5 (mm)	L6 (mm)	L7 (mm)	L8 (mm)
124	160	56	130	25	77	83	122	33
144	160	65	150	25	77	83	122	33
154	160	71	160	25	77	83	122	33
174	160	85	180	45	77	83	122	33
194	160	89	200	45	77	83	122	33
224	160	101	230	45	77	83	122	33

Type 179 – 184 with solvent cement sockets, metric

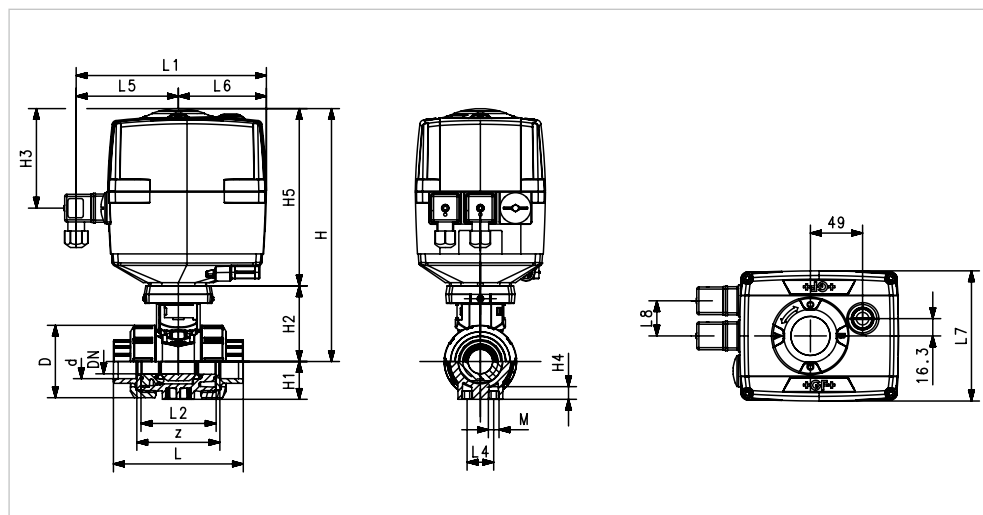

d (mm)	DN (mm)	D (mm)	H (mm)	H1 (mm)	H2 (mm)	H3 (mm)	H5 (mm)
16	10	50	231	27	60	94	167
20	15	50	231	27	60	94	167
25	20	58	240	30	73	94	167
32	25	68	240	36	70	94	167
40	32	84	251	44	84	94	167
50	40	97	251	51	84	94	167
63	50	124	273	64	106	94	167
75	65	166	346	85	156	94	190
90	80	200	358	105	168	94	190
110	100	238	365	123	175	94	190

L (mm)	L1 (mm)	L2 (mm)	L4 (mm)	L5 (mm)	L6 (mm)	L7 (mm)	z (mm)
92	180	56	25	97	83	122	64
95	180	56	25	97	83	122	64
110	180	65	25	97	83	122	72
123	180	71	25	97	83	122	79
146	180	85	45	97	83	122	94
157	180	89	45	97	83	122	95
183	180	101	45	97	83	122	107
233	180	136	70	98	83	122	144
254	180	141	70	98	83	122	151
301	180	164	120	98	83	122	174

Type 179 – 184 backing flanges PP ST, metric

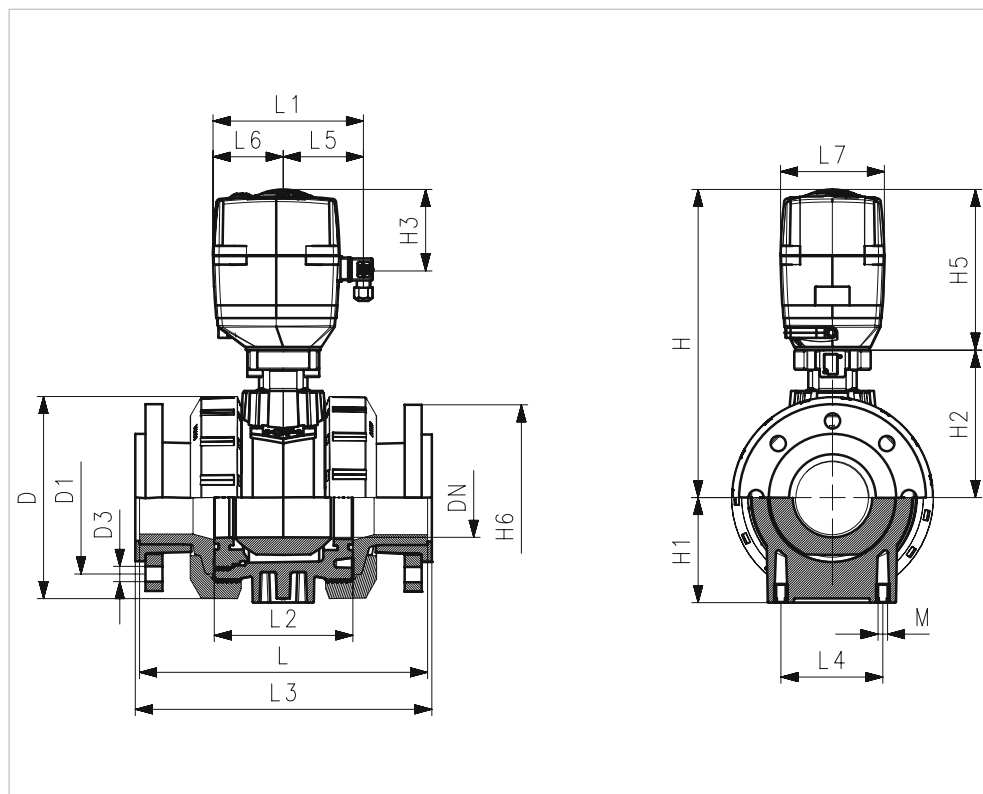

d (mm)	DN (mm)	D (mm)	H (mm)	H1 (mm)	H2 (mm)	H3 (mm)	H5 (mm)	H6 (mm)
75	65	166	346	85	156	94	190	93
90	80	200	358	105	168	94	190	100
110	100	238	365	123	175	94	190	110

L (mm)	L1 (mm)	L2 (mm)	L3 (mm)	L4 (mm)	L5 (mm)	L6 (mm)	L7 (mm)	L8 (mm)
284	180	136	290	70	98	83	122	66
300	180	141	310	70	98	83	122	66
340	180	164	350	120	98	83	122	66

Accessories

EA15 / EA25 / EA45 / EA120 / EA250:

- Fail-safe return unit with or without integrated battery package
- AS-interface plug on module
- Limit switch assembly kits for multi function module AgNi, Au, NPN, PNP

EA25 / EA45 / EA120 / EA250:

- Monitoring board with cycle time extension, cycle time monitoring, cycle cycle time monitoring, cycle counter and motor current monitoring
- Positioner board for modulating operation with 4-20 mA Feedback and integrated motor current monitoring
- Profibus DP V0 plug-on module



For further information on accessories, refer to the online product catalog at www.gfps.com

Ball Valve type 546 Pro, electric actuated (Type 104)



Type 104

With electric actuator EA04

Product description

Available in PVC-U, PVC-C and PP-H, the Ball Valve type 104 from GF Piping Systems is an efficient solution for less demanding applications. type 104 is based on the same industrial ball type valve that GF Piping Systems utilizes in other applications. This means that the valve can be removed and serviced. With a duty cycle of 75 %, the valve is suited for a low to median number of actuations.

Applications

- Chemical process industry
- Microelectronics
- Measurement and control
- Shipbuilding
- Food & beverage

Benefits/features

- Optical position indicator
- Integrated emergency manual override
- Multi-colour led status light as standard
- Integrated mounting inserts for attaching the valve
- All actuators have the CE marking.

Flow media

Neutral and aggressive media with a small amount of particles/solids. The chemical resistance depends on the selected valve material ([see online tool ChemRes PLUS](#)).

Technical data

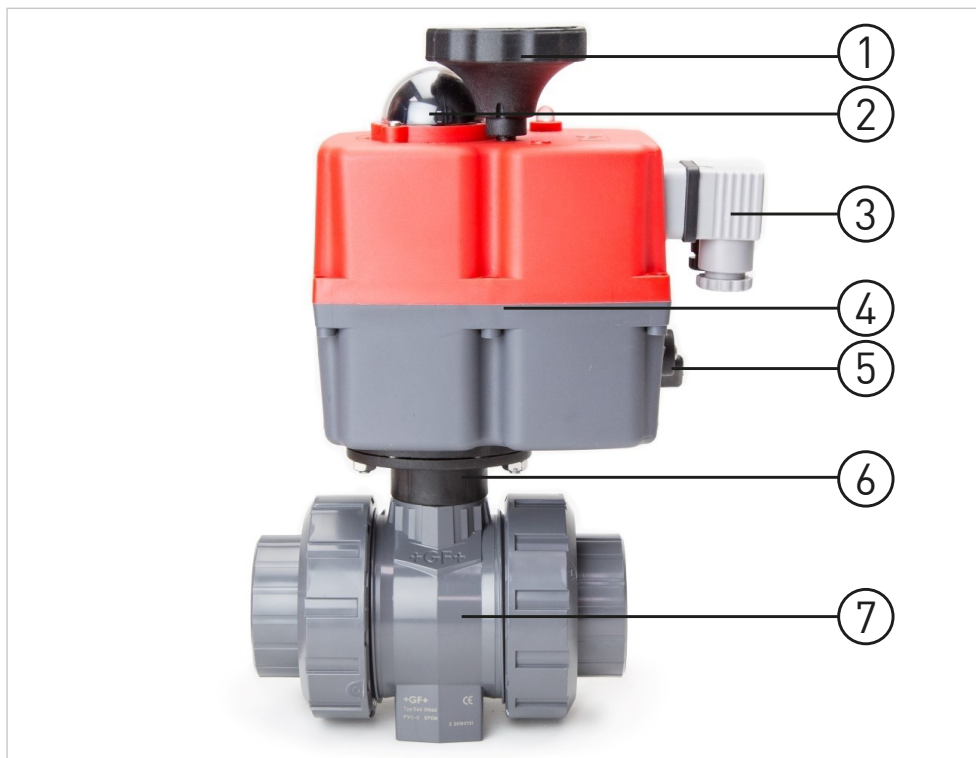

- 1 Emergency manual override
- 2 Position indicator
- 3 Connection for control voltage/feedback
- 4 Electric actuator EA04
- 5 Switch emergency manual override
- 6 Assembly kit
- 7 Ball Valve Type 546 Pro

Specification

Dimensions	Type 104	EA04	d16/DN10 – d63/DN50
Ball valve	Type 546 Pro		
Materials	PVC-U, PVC-C, PP-H		
Gasket materials	EPDM, FKM		
Pressure rating	PN10		
Connections	Socket, Spigot, NPT thread		
Nominal torque	20Nm		
Voltage	85 - 240 V AC/DC		
Standards	ISO, BS, ASTM, JIS		



The following technical data can be found in the Planning Fundamentals under "Ball Valve type 546 Pro, manually operated":

- Pressure-temperature diagram
- Pressure loss
- Flow characteristics
- Kv values
- Reference values for screw fastenings

Technical basics

Valve handling

Installation notes

During installation, ensure that the actuator is correctly built onto and connected to the correct valve.

The following points must be observed:

- Actuate valves with 90° rotary movement
- Indicate the previously calibrated end positions of the valve via electrical signal to the aforementioned system control
- In case of interruption in the power supply, ensure that the actuator remains in the current position. For this, installation of an emergency manual override or reset unit is recommended

Maintenance notes

Set maintenance intervals as per the conditions of use (e. g. actuating cycles, medium, ambient temperature). As part of the regular system inspection, carry out the following maintenance activities:

- Regularly check that no medium escapes to the outside
- We recommend a function test for ball valves that are kept permanently in the same position 1 – 2 times per year to check functionality
- Check that cover of the emergency manual override is correctly fitted. If necessary, fit cover
- Check that housing cover of the actuator is fitted with all screws. Insert screws if necessary
- Check if grating noises are coming from the actuator. Replace actuator, see assembly instructions for installing ball valve with electric actuator
- Check that position display matches signal from the controller
- If necessary, adjust limit switches

For frequent control operations or due to chemical attack on the sealing material, it may become necessary to replace parts inside the valve.



Installation and maintenance must be performed according to the corresponding installation instructions. The installation manual is included with the product, see also the online product catalog at www.gfps.com

Ball Valve type 546 Pro P, pneumatic actuated

		
<p>Type 546 Pro P, DN10-DN50 with pneumatic actuator PA08-40, without manual override</p>	<p>Type 546 Pro P, DN10-DN50 with pneumatic actuator PPA08-40, with manual override</p>	<p>Type 546 Pro P, DN65-DN100 with pneumatic actuator PA80, without manual override</p>

Product description

The pneumatic actuated ball valve series is modularly configurable and designed for applications that require special process requirements. It is based on the ball valve 546 Pro and the pneumatic actuators PPA08, PPA15, PPA40 and PPA80.

Applications

- Chemical process industry
- Water treatment
- Microelectronics
- Measurement and control
- Shipbuilding
- Cooling

Benefits/features

- Electrical position feedback at the stem of the valve (via optional PNP or NPN double sensor)
- Full plastic solution (housing of PPA actuator made of PP-GF)
- Long service life with more than 50,000 cycles
- Pressure control connection based on NAMUR standard
- Optional with emergency manual override
- Compact design
- Optional positioner and solenoid valve

Flow media

Neutral and aggressive media with a small amount of particles/solids. The chemical resistance is dependent on the selected valve material ([see online tool ChemRes PLUS](#)).

Technical data

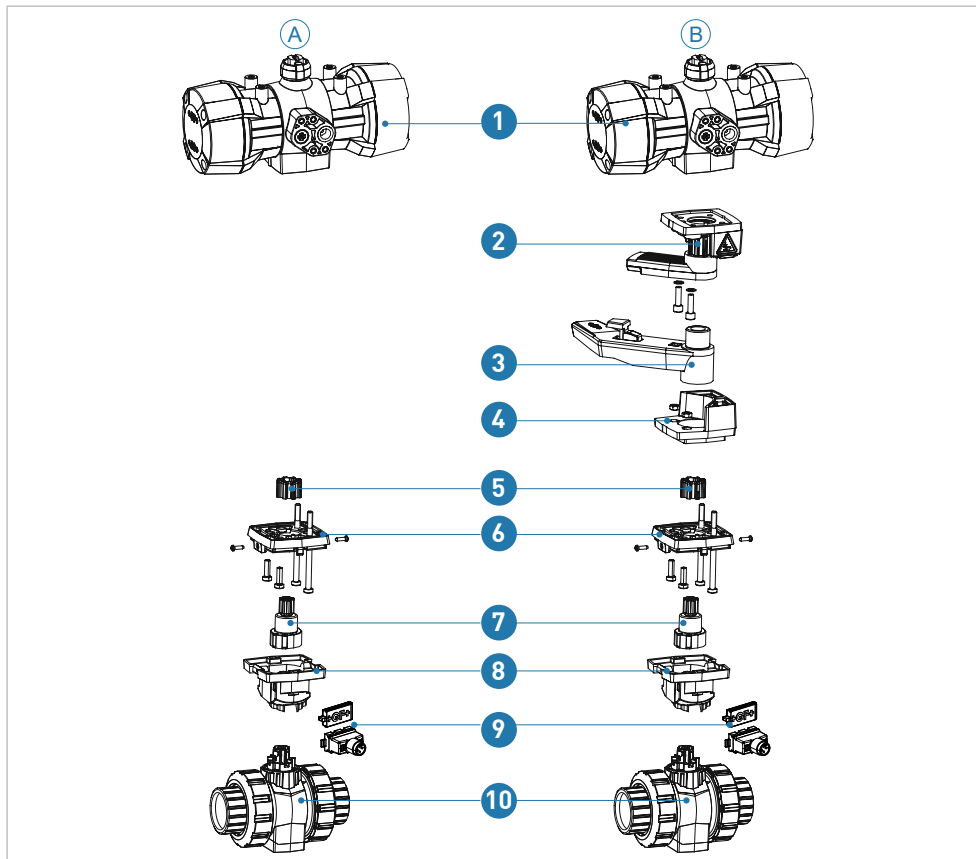

- A** Type 546 Pro P, with pneumatic actuator type PPA, without manual override
- B** Type 546 Pro P, with pneumatic actuator type PPA, with manual override
- 1** Actuator type PPA
- 2** Coupling lever with upper intermediate element
- 3** Control lever
- 4** Lower intermediate element
- 5** Adapter
- 6** Adapter plate
- 7** Coupling piece
- 8** Interface housing
- 9** Labelling clip or double sensor for electrical position feedback
- 10** Ball Valve Type 546 Pro

Specification

Dimensions (standard 5.6 bar)	PPA08	DN10 – DN20
	PPA15	DN25 – DN32
	PPA40	DN40 – DN50
	PPA80	DN65 – DN100
Base type	546 Pro	
Materials	PVC-U, PVC-C, ABS, PP-H, PVDF	
Gasket materials	O-rings	EPDM, FKM (other sealings on request)
	Ball seat	PTFE, PVDF
Pressure rating	PN10	
Connections	Socket, spigot, flanges, threaded socket	
Standards	ISO, BS, ASTM, JIS	

i The following technical data can be found in the Planning Fundamentals under Ball Valve type 546 Pro, manually operated:

- Pressure-temperature diagram
- Pressure loss
- Flow characteristics
- Kv values
- Reference values for fastening screws

Technical basics

- The actuators are available with the functions fail-safe to close (FC), fail-safe to open (FO) or double-acting (DA) and are provided with an optical position indicator.
- The housing of the actuator is made of fiberglass-reinforced polypropylene (PP-GF) and therefore has low flammability.
- For simple installation of positioners, limit switches and accessories, the actuators have an integrated NAMUR interface. For reliable electrical feedback, the valves are equipped with an interface module that is installed between valve body and actuator.

Valve handling

Installation notes

- The type 546 Pro P ball valves can be controlled to the OPEN and CLOSED positions via a built-on solenoid valve. The solenoid valve is either supplied ex GF works or installed by the customer.
- The OPEN and CLOSED positions can be indicated by the double sensor (available as an accessory), which send an electric signal to the plant control system or optically output the valve position (red/green LED).

Maintenance notes

Ball valves require few maintenance under normal operating conditions (clear water).

However, the following measures must be considered:

- Regularly check that no medium escapes to the outside.
- We recommend a function test for ball type valves that are kept permanently in the same position 1 – 2 times per year to check functionality.

For frequent control operations or due to chemical attack on the sealing material, it may become necessary to replace parts inside the valve or the complete valve/ central part. For this purpose, the valve must be removed from the piping system.



Installation and maintenance must be performed according to the corresponding installation instructions. The installation manual is part of the product, see also the online product catalog at www.gfps.com

Dimensions

Type 546 Pro P (DN10 – DN50) with manual override, sockets

Ball Valve type 546 Pro, with sockets, metric with pneumatic actuators PPA08-80 with emergency manual override.

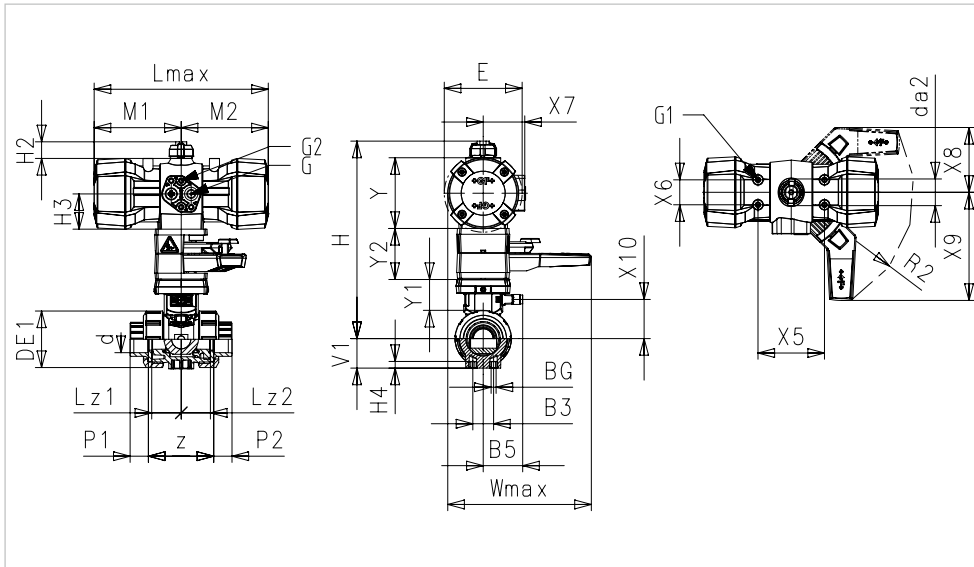

DN (mm)	d (mm)	Actuator	da2 (mm)	B3 (mm)	BG (mm)	DE1 (mm)	E (mm)	G1 (mm)	G2 (mm)	G (inch)	H2 (mm)	H3 (mm)	H4 (mm)	H (mm)
10	16	PPA08	33	25	M6	50	74	M5	M5	G 1/4	20	41	12	175
15	20	PPA08	33	25	M6	50	74	M5	M5	G 1/4	20	41	12	175
20	25	PPA08	33	25	M6	58	74	M5	M5	G 1/4	20	41	12	179
25	32	PPA15	33	25	M6	68	94	M5	M5	G 1/4	20	45	12	198
32	40	PPA15	33	45	M8	84	94	M5	M5	G 1/4	20	45	15	204
40	50	PPA40	33	45	M8	97	120	M5	M5	G 1/4	20	56	15	233
50	63	PPA40	33	45	M8	124	120	M5	M5	G 1/4	20	56	15	248

DN (mm)	Lz1 (mm)	Lz2 (mm)	Lmax (mm)	M1 (mm)	M2 (mm)	P1 (mm)	P2 (mm)	V1 (mm)	Wmax (mm)	X5 (mm)	X6 (mm)	X7 (mm)	X10 (mm)	Y1 (mm)	Y (mm)	z (mm)
10	28	28	159	80	80	13	13	27	77	80	30	43	35	35	95	67
15	28	28	159	80	80	14	14	27	77	80	30	43	35	35	95	67
20	33	33	159	80	80	16	16	30	77	80	30	43	35	35	95	76
25	36	36	211	106	106	18	18	36	93	80	30	51	35	35	108	82
32	43	43	211	106	106	20	20	44	93	80	30	51	33	33	108	97
40	45	45	246	123	123	23	23	51	117	80	30	62	33	33	131	101
50	51	51	246	123	123	27	27	64	117	80	30	62	36	36	131	114

Type 546 Pro P (DN10 – DN50) without manual override, sockets

Ball Valve type 546 Pro, with sockets, metric with pneumatic actuator PPA08-80.

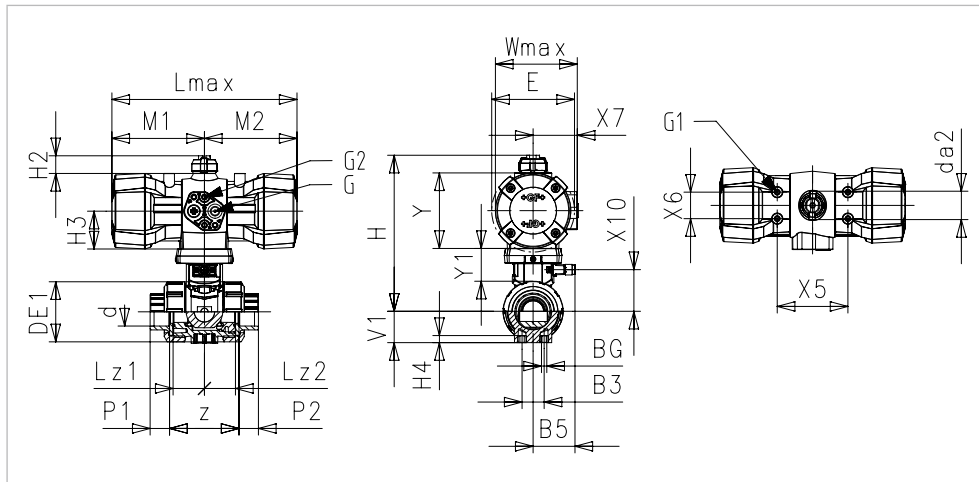

DN (mm)	d (mm)	Actuator	da2 (mm)	DE1 (mm)	E (mm)	G1 (mm)	G2 (mm)	G (inch)	H (mm)	H2 (mm)	H3 (mm)	H4 (mm)
10	16	PPA08	33	50	74	M5	M5	G 1/4	175	20	41	12
15	20	PPA08	33	50	74	M5	M5	G 1/4	175	20	41	12
20	25	PPA08	33	58	74	M5	M5	G 1/4	179	20	41	12
25	32	PPA15	33	68	94	M5	M5	G 1/4	198	20	45	12
32	40	PPA15	33	84	94	M5	M5	G 1/4	204	20	45	15
40	50	PPA40	33	97	120	M5	M5	G 1/4	233	20	56	15
50	63	PPA40	33	124	120	M5	M5	G 1/4	248	20	56	15

DN (mm)	Lmax (mm)	M1 (mm)	M2 (mm)	P1 (mm)	P2 (mm)	V1 (mm)	Wmax (mm)	X5 (mm)	X6 (mm)	X7 (mm)	X10 (mm)	Y1 (mm)	Y (mm)	z (mm)
10	159	80	80	13	13	27	77	80	30	43	35	35	95	88
15	159	80	80	14	14	27	77	80	30	43	35	35	95	96
20	159	80	80	16	16	30	77	80	30	43	35	35	95	111
25	211	106	106	18	18	36	93	80	30	51	35	35	108	118
32	211	106	106	20	20	44	93	80	30	51	33	33	108	133
40	246	123	123	23	23	51	117	80	30	62	33	33	131	147
50	246	123	123	27	27	64	117	80	30	62	36	36	131	169

Type 546 Pro P (DN10 – DN50) without manual override, spigots/flanges

Ball Valve type 546 Pro, with spigots/flanges, metric with pneumatic actuator PPA08-80.

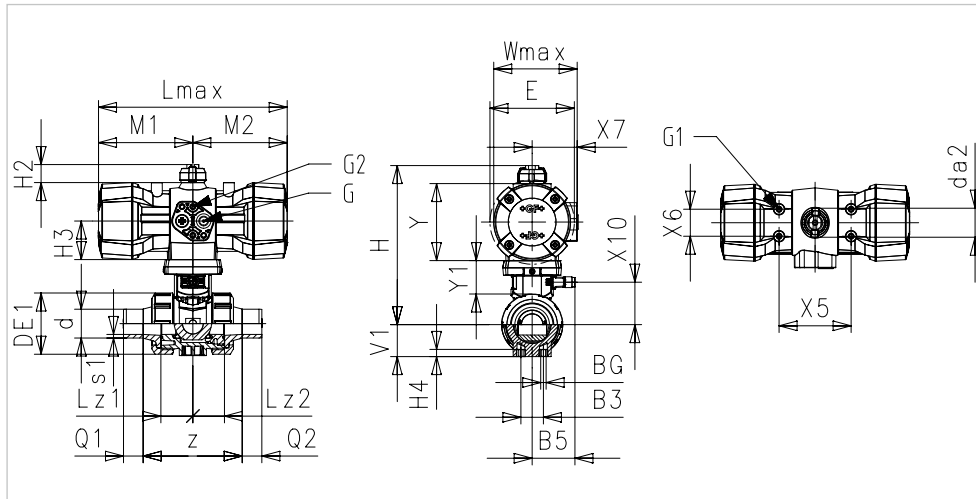

DN (mm)	d (mm)	Actuator	B3 (mm)	BG (mm)	da2 (mm)	DE1 (mm)	E (mm)	G1 (mm)	G2 (mm)	G (inch)	H (mm)	H2 (mm)	H3 (mm)	H4 (mm)
10	16	PPA08	25	M6	33	50	74	M5	M5	G 1/4	235	20	41	12
15	20	PPA08	25	M6	33	50	74	M5	M5	G 1/4	235	20	41	12
20	25	PPA08	25	M6	33	58	74	M5	M5	G 1/4	239	20	41	12
25	32	PPA15	25	M6	33	68	94	M5	M5	G 1/4	258	20	45	12
32	40	PPA15	45	M8	33	84	94	M5	M5	G 1/4	264	20	45	15
40	50	PPA40	45	M8	33	97	120	M5	M5	G 1/4	293	20	56	15
50	63	PPA40	45	M8	33	124	120	M5	M5	G 1/4	308	20	56	15

DN (mm)	Lmax (mm)	M1 (mm)	M2 (mm)	Q1 (mm)	Q2 (mm)	R2 (mm)	V1 (mm)	Wmax (mm)	X5 (mm)	X6 (mm)	X7 (mm)	X8 (mm)	X9 (mm)	X10 (mm)	Y1 (mm)	Y2 (mm)	Y (mm)	z (mm)
10	159	80	80	21	21	R150	27	210	80	30	43	78	132	35	35	60	95	88
15	159	80	80	17	17	R150	27	210	80	30	43	78	132	35	35	60	95	96
20	159	80	80	20	20	R150	30	210	80	30	43	78	132	35	35	60	95	111
25	211	106	106	21	21	R150	36	210	80	30	51	78	132	35	35	60	108	118
32	211	106	106	24	24	R150	44	210	80	30	51	78	132	33	33	60	108	133
40	246	123	123	27	27	R150	51	210	80	30	62	78	132	33	33	60	131	147
50	246	123	123	31	31	R150	64	210	80	30	62	78	132	36	36	60	131	169

Type 546 Pro P (DN65 – DN100) without manual override, sockets

Ball Valve type 546 Pro, with sockets, metric with pneumatic actuator PPA80 with stroke limiter

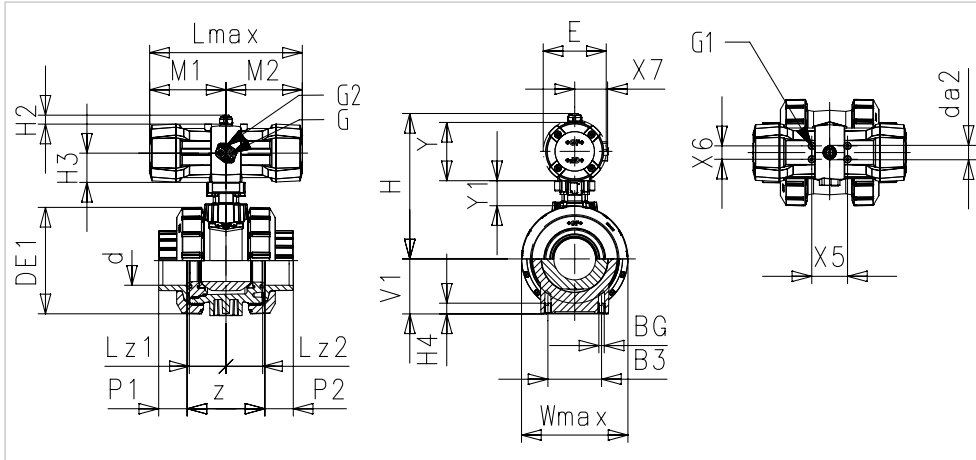

DN (mm)	d (mm)	Actuator	B3 (mm)	BG (mm)	da2 (mm)	DE1 (mm)	E (mm)	G1 (mm)	G2 (mm)	G (inch)	H (mm)	H2 (mm)	H3 (mm)	H4 (mm)
65	75	PPA80	70	M8	33	166	142	M5	M5	G 1/4	327	20	66	15
80	90	PPA80	70	M8	33	200	142	M5	M5	G 1/4	339	20	66	15
100	110	PPA80	120	M12	33	238	142	M5	M5	G 1/4	346	20	66	22

DN (mm)	Lz1 (mm)	Lz2 (mm)	Lmax (mm)	M1 (mm)	M2 (mm)	P1 (mm)	P2 (mm)	Wmax (mm)	X6 (mm)	X5 (mm)	X7 (mm)	Y (mm)	V1 (mm)	z (mm)
65	68	68	343	172	172	33	33	139	30	80	74	151	85	167
80	71	71	343	172	172	37	37	139	30	80	74	151	105	180
100	82	82	343	172	172	43	43	139	30	80	74	151	123	215

Type 546 Pro P (DN65 – DN100) without manual override, spigots/flanges

Ball Valve type 546 Pro, with spigots/flanges, metric with pneumatic actuators PPA80 with stroke limiter

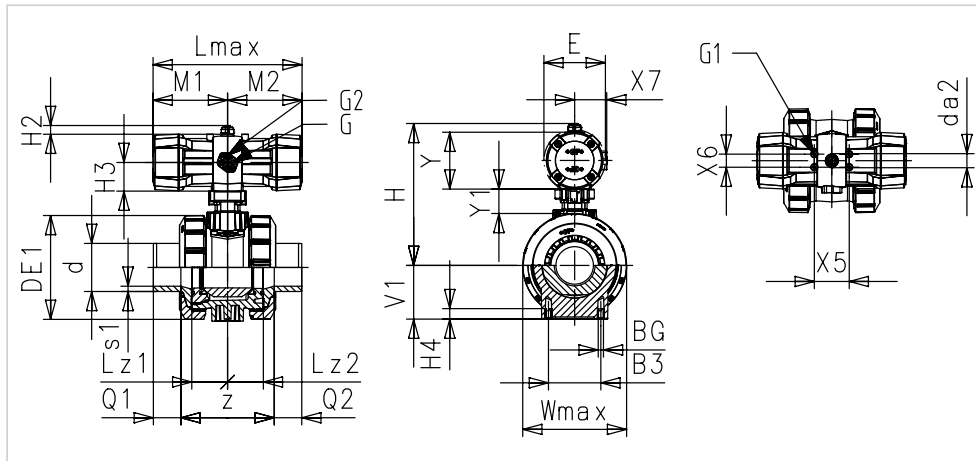

DN (mm)	d (mm)	Actuator	B3 (mm)	BG (mm)	da2 (mm)	DE1 (mm)	E (mm)	G1 (mm)	G2 (mm)	G (inch)	H (mm)	H2 (mm)	H3 (mm)	H4 (mm)
65	75	PPA80	70	M8	33	166	142	M6	M5	G 1/4	327	20	66	15
80	90	PPA80	70	M8	33	200	142	M7	M5	G 1/4	339	20	66	15
100	110	PPA80	120	M12	33	238	142	M8	M5	G 1/4	346	20	66	22

DN (mm)	Lmax (mm)	M1 (mm)	M2 (mm)	Q1 (mm)	Q2 (mm)	V1 (mm)	Wmax (mm)	X5 (mm)	X6 (mm)	X7 (mm)	Y (mm)	z (mm)
65	343	172	172	53	53	85	139	80	30	74	151	184
80	343	172	172	56	56	105	139	80	30	74	151	199
100	343	172	172	52	52	123	139	80	30	74	151	226

Accessories

- Emergency manual override -10 up to +50 °C
- Double sensor for electrical position feedback
- 3/2-way pilot solenoid valve type PV94/95
- 3/2 – 5/2-way pilot solenoid valve type MNL532
- 4/2-way pilot solenoid valve type 5470
- Pilot valve cluster type PV2000
- Digital positioner type RPC
- Position indicator – Feedback box
- AS-Interface
- See accessories for pneumatic actuator PPA

i For further information on accessories, refer to the online product catalog at www.gfps.com

The information and technical data (altogether "Data") herein are not binding, unless explicitly confirmed in writing. The Data neither constitutes any expressed, implied or warranted characteristics, nor guaranteed properties or a guaranteed durability. All Data is subject to modification. The General Terms and Conditions of Sale of Georg Fischer Piping Systems apply.

12/2024-A

© Georg Fischer Piping Systems Ltd, 8201 Schaffhausen/Switzerland
Tel. +41 52 631 11 11 • www.gfps.com • E-Mail: info.ps@georgfischer.com