

Type 8745 Industrial Ethernet / Analogue

Mass Flow Meter (MFM) / Mass Flow Controller (MFC)
Massendurchflussmesser (MFM) / Massendurchflussregler (MFC)
Débitmètre massique (MFM) / Régulateur de débit massique (MFC)



Operating Instructions

Bedienungsanleitung
Manuel d'utilisation

We reserve the right to make technical changes without notice.
Technische Änderungen vorbehalten.
Sous réserve de modifications techniques.

© Bürkert SAS, 2017

Operating Instructions 1710/00_EU-ML_00569558 / Original EN

1	THE OPERATING INSTRUCTIONS	5	6	TECHNICAL DATA	15
1.1	Definition of terms	5	6.1	Conformity	15
1.2	Symbols used	5	6.2	Standards	15
2	INTENDED USE	6	6.3	Operating conditions	15
3	BASIC SAFETY INFORMATION	6	6.4	Mechanical data	16
4	GENERAL INFORMATION	8	6.5	Fluid data.....	16
4.1	Manufacturer's name and address, international contacts	8	6.6	Electrical data of an Ethernet version	18
4.2	Warranty	8	6.7	Electrical data of an analogue version.....	18
4.3	Information on the Internet	8	6.8	Markings	19
5	DESCRIPTION	8	6.9	Communication interface: Industrial Ethernet	21
5.1	Design of an MFM	8	7	INSTALLATION	22
5.2	Design of an MFC with solenoid valve	9	7.1	Safety instructions	22
5.3	Design of an MFC with motor valve	10	7.2	Additional documentation	22
5.4	Product status LED.....	10	7.3	Recommendations before installation	22
5.5	LED to indicate the motor valve status.....	12	7.4	Mechanical installation	23
5.6	LED's for the connection to the Ethernet network.....	12	7.5	Fluid system installation	23
5.7	Communication LED (Ethernet version)	13	7.6	Electrical installation	25
5.8	büS service interface and Bürkert-Communicator (PC software)	13	7.7	Setting the Industrial Ethernet address (only Ethernet version).....	28
5.9	Replaceable configuration memory	13	8	COMMISSIONING	28
5.10	Operating principle of the MFC (Mass Flow Controller).....	14	8.1	Safety instructions	28
5.11	Proportional valve of an MFC	14	9	OPERATION	29
			9.1	Safety instructions.....	29
			9.2	Changing the fieldbus address (only Ethernet version).....	29
			9.3	Normal control mode (MFC)	29
			9.4	Optimising the control parameters (MFC)	30

9.5	Digital input (analogue version with a D-sub DE-9 plug).....	30	14	TRANSPORT	42
9.6	Relay output (analogue version with a D-sub DE-9 plug).....	31	15	STORAGE, DISPOSAL	42
9.7	Zero point shut-off (MFC)	31	16	RETURNING THE PRODUCT	43
9.8	Specifying the source giving the set-point value (MFC)	32			
9.9	User-defined calibration	32			
9.10	Flush mode (MFC, Ethernet version only).....	32			
9.11	Set-point values without communication (MFC, Ethernet version only)	33			
10	MAINTENANCE.....	33			
10.1	Maintenance for operation with heavily contaminated media.....	33			
10.2	Cleaning and recalibration at the factory.....	35			
10.3	Replacing the configuration memory.....	35			
11	PRODUCT STATUS/TROUBLESHOOTING	36			
11.1	Display of the product status.....	36			
11.2	Troubleshooting	37			
11.3	Troubleshooting for the motor valve.....	39			
12	ACCESSORIES /SPARE PARTS	40			
12.1	Electrical Accessories.....	40			
12.2	Compression fittings.....	40			
13	DECOMMISSIONING.....	41			
13.1	Safety instructions.....	41			
13.2	Dismantling the product	41			

1 THE OPERATING INSTRUCTIONS

The Operating Instructions describe the entire life cycle of the product. Please keep the Operating Instructions in a safe place, accessible to all users and any new owners.

Important safety information!

Please read the manual carefully. Pay particular attention to the sections „Basic safety information“ and „Intended use“.

- ▶ The Operating Instructions must be read and understood.

1.1 Definition of terms

- The term "product" as used in the Operating Instructions, always refers to the MFM/MFC type 8745 Ethernet or type 8745 analogue.
- The term "Industrial Ethernet" as used in the Operating Instructions, refers to devices that communicate with the fieldbus protocols PROFINET, EtherNet/IP, EtherCAT or Modbus TCP.

1.2 Symbols used

The following symbols are used in the Operating Instructions.



DANGER

Warns of immediate danger!

- ▶ If ignored, death or serious injury will result.



WARNING

Warns of a situation which is possibly dangerous!

- ▶ If ignored, serious injury or death may result.



CAUTION

Warns of a possible danger!

- ▶ Failure to observe this warning can result in substantial or minor injuries.

NOTE!

Warns of damage to property!



Important advice and recommendations.



Refers to information in the Operating Instructions, or in other documents.

- ▶ Indicates an instruction to be carried out to avoid a danger.

→ Indicates a procedure that must be carried out.



Indicates a result.

Menu Identifies a text of a user interface.

2 INTENDED USE

Improper use of the product may be a hazard to people, nearby equipment and the environment.

MFM type 8745 is used exclusively to measure the mass flow of clean dry gases.

MFC type 8745 is used exclusively to control the mass flow of clean dry gases.

- ▶ Observe the additional data, operating and service conditions specified in the contract documents, the Operating Instructions and on the rating plate and calibration plate.

The product

- ▶ Use only for the media indicated on the rating plate and in the calibration protocol.
- ▶ Only use indoors.
- ▶ Only use up to an altitude of 2000 m.
- ▶ Use only in conjunction with external instruments and components recommended by Bürkert.
- ▶ Operate carefully and ensure regular, professional maintenance.
- ▶ Operate only in perfect working order and ensure appropriate storage, transport, installation and control.
- ▶ Use only for its intended purpose.

3 BASIC SAFETY INFORMATION

This safety information does not take into account any contingencies or occurrences that may arise during installation, use and maintenance of the product.

The operating company is responsible for the respect of the local safety regulations including for the personnel safety.



Risk of injury due to high pressure in the installation/product.

- ▶ Before working on the installation or product, cut the pressure and vent and drain the pipes.

Risk of injury from electric shocks.

- ▶ Before working on the installation or product, switch off the power and ensure that it cannot be reactivated.
- ▶ Observe the applicable accident protection and safety regulations for electrical equipment!

Burns/fire hazard due to hot surface of the product!

- ▶ Do not touch the hot surface with bare hands.
- ▶ Wear safety gloves to touch the product.
- ▶ Keep the product away from any highly flammable materials or media.

Danger due to escape of the medium.

- ▶ Observe the applicable accident protection and safety regulations relating to the operating medium used.

Various dangerous situations.

To avoid personal injury:

- ▶ Do not operate the product without the factory installed mesh filter.
- ▶ Only operate the product in the installation position given on the calibration plate.
- ▶ Make sure the operating pressure of the product is not higher than the maximum calibration pressure (MFM) specified on the calibration plate or the tightness pressure of the proportional valve (MFC).
- ▶ Only use the product for the medium specified as the operating medium in the calibration protocol.
- ▶ Only use agents that are stable with the product materials for cleaning and decontamination
The compatibility chart can be found on our homepage: www.burkert.com
In the event of any ambiguity please contact your local sales office.
- ▶ Do not make any modifications to the product and do not subject the product to mechanical loads.
- ▶ Protect the installation/product from accidental actuation.
- ▶ Only trained personnel may perform installation and maintenance work.
- ▶ After an interruption in the electrical and media supply, ensure a controlled restart of the process.
- ▶ Observe best industry practice.

NOTE!

Components / assemblies at risk from electrostatic charges!

The product contains electronic components which are susceptible to electrostatic discharge (ESD). Contact with electrostatically charged persons or objects endangers these components. In the worst case, they will become defective immediately or will fail when energized.

- To minimise or even avoid all damage due to an electrostatic discharge, take all the precautions described in the EN 61340-5-1.
- Do not touch any of the live electrical components.

4 GENERAL INFORMATION

4.1 Manufacturer's name and address, international contacts

The name of the manufacturer is displayed as inset writing on the cover and the housing of the product.

The manufacturer of the product can be contacted at the following address:

Bürkert SAS
Rue du Giessen
F-67220 TRIEMBACH-AU VAL

The addresses of our international sales offices are available on the internet at: www.burkert.com

4.2 Warranty

The warranty is conditional on compliant use of the product in observance of the operating conditions specified in the Operating Instructions.

4.3 Information on the Internet

Operating manuals and data sheets for the type 8745 can be found online at: www.burkert.com

5 DESCRIPTION

5.1 Design of an MFM

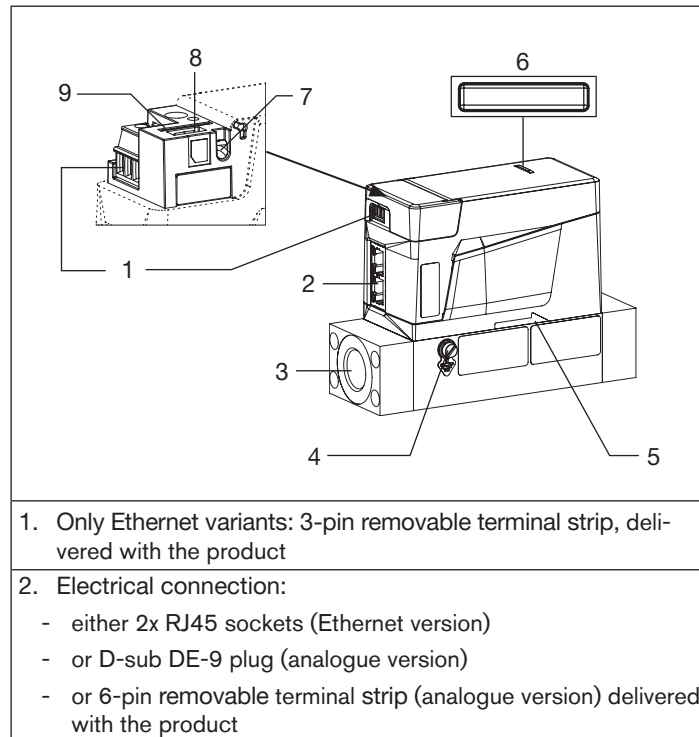

3. Fluid connection
4. M4 screw for functional earth connection
5. Flow direction
6. Product status LED (according to Namur NE 107)
7. Communication LED (Ethernet version)
8. bÜS interface (service only)
9. Slot for the configuration memory

Fig. 1: Description of the MFM type 8745

5.2 Design of an MFC with solenoid valve

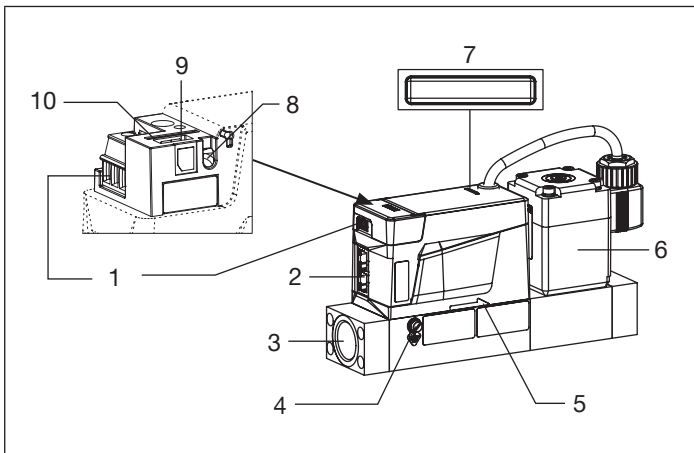

1. Only Ethernet variants: 3-pin removable terminal strip, delivered with the product
2. Electrical connection: <ul style="list-style-type: none"> - either 2x RJ45 sockets (Ethernet version) - or D-sub DE-9 plug (analogue version) - or 6-pin removable terminal strip (analogue version) delivered with the product
3. Fluid connection
4. M4 screw for functional earth connection
5. Flow direction
6. Solenoid valve
7. Product status LED (according to Namur NE 107)
8. Communication LED (Ethernet version)
9. bÜS interface (service only)
10. Slot for the configuration memory

Fig. 2: Description of the MFC with solenoid valve, type 8745

5.3 Design of an MFC with motor valve

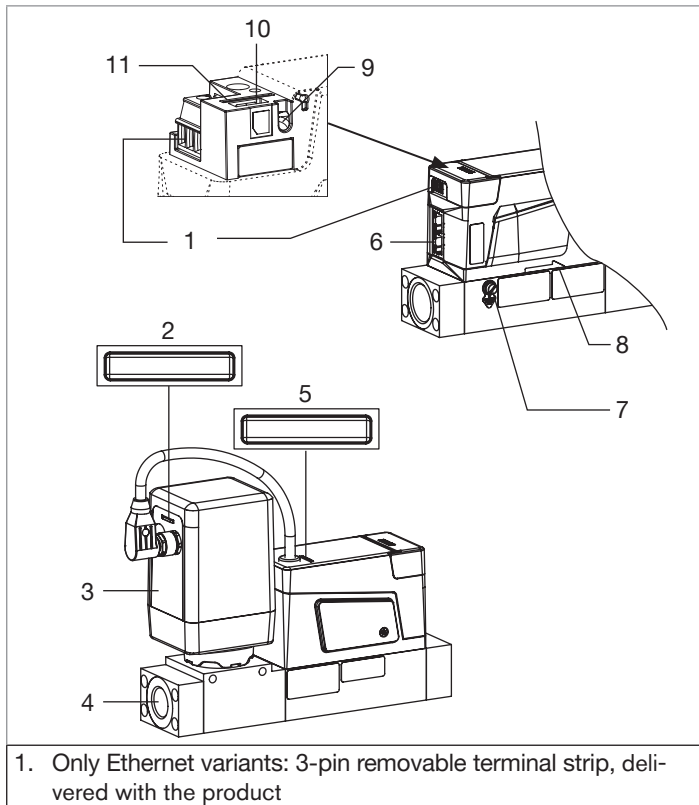

2. LED to display the status of the motor valve
3. Electromotive proportional valve (if deenergized, remains in the current position)
4. Fluid connection
5. Product status LED (according to Namur NE 107)
6. Electrical connection: <ul style="list-style-type: none"> - either 2x RJ45 sockets (Ethernet version) - or D-sub DE-9 plug (analogue version) - or 6-pin removable terminal strip (analogue version) delivered with the product
7. M4 screw for functional earth connection
8. Flow direction
9. Communication LED (Ethernet version)
10. büS interface (service only)
11. Slot for the configuration memory

Fig. 3: Design of the MFC with motor valve, type 8745

5.4 Product status LED

The product has an LED to display the product status depending on their colour and status.

If more than one product status exists simultaneously, the product status with the highest priority is displayed.

LED according to NE 107	Colour code (for a PLC)	Description	Meaning
Red	5	Failure, error or fault	Due to a malfunction of the product or its periphery, the measured values (of an MFM) is not valid or the controlled operation (of an MFC) is not possible.
Orange	4	Function check	The product is being worked on; output signal (of an MFM) is therefore temporarily invalid or the controlled operation (of an MFC) is therefore temporarily not possible.
Yellow	3	Out of specification	The ambient conditions or process conditions for the product are outside the specified ranges. Product internal diagnostics point to problems in the product or with the process properties.
Blue	2	Maintenance required	The product continues to measure (MFM) or is in controlled operation (MFC), however a function is temporarily restricted. Do the required maintenance operation.
Green	1	Diagnostic active	No event has been generated. Status changes are shown in color. Messages are listed and possibly transmitted via any connected fieldbus.
White	0	Diagnostic inactive	The product is switched on. Status changes are not shown. Messages are not listed nor transmitted via any connected fieldbus.

Tab. 1: Description of the product status LED

When the LED is blinking, a connection between the product and the Bürkert-Communicator software is established.

 A detailed description of the displayed product status and see chap. [11.1 Display of the product status on page 36](#)

5.5 LED to indicate the motor valve status

An MFC with motor valve has a second LED to indicate the status of the motor valve; the colour and the status of the LED are described in the following table.

Colour of the LED	Status	Status of the motor valve
none	LED out	Valve is not energized
white	lit	Normal operation
yellow	lit	Valve completely open
green	lit	Valve closed
red	flashing, colour alternating with the colours indicating the valve position	Error
yellow	flashing, colour alternating with the colours indicating the valve position	Out of specification: the ambient conditions or process conditions for the motor valve are outside the specified ranges.

Tab. 2: Description LED motor valve status

5.6 LED's for the connection to the Ethernet network

An Industrial Ethernet version has 2 LED's on each RJ45 socket to show the status of the connection to the network.

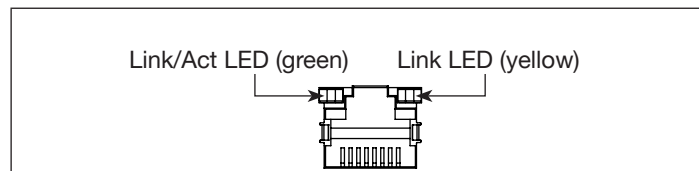

Fig. 4: Location and description of the LED's of an RJ45 socket

Link/Act LED	Meaning
ON, fast blinking	Connection to the parent protocol layer is established. Data are being exchanged.
ON, slow blinking	No connection to the protocol layer. Happens about 20 seconds after restart of the product.
OFF	No connection to the network.

Tab. 3: Description of the Link/Act LED

Link LED	Meaning
ON	Connection to the network is established.
OFF	No connection to the network.

Tab. 4: Description of the Link LED

5.7 Communication LED (Ethernet version)

An Industrial Ethernet version has an LED to show the status of the communication between the product and the PLC (Programmable Logical Controller).

Communication LED	Description	Meaning
Green	RUN	Connection to the PLC is active.
Red	ERROR	Connection to the PLC is inactive.

Tab. 5: Description of the communication LED of an Ethernet version

5.8 bÜS service interface and Bürkert-Communicator (PC software)

The bÜS service interface can be used for a short-term service. To use the bÜS service interface and the Bürkert-Communicator software which runs under Windows, you must have the bÜS stick set, available as an accessory (see [12.1 Electrical Accessories](#)).

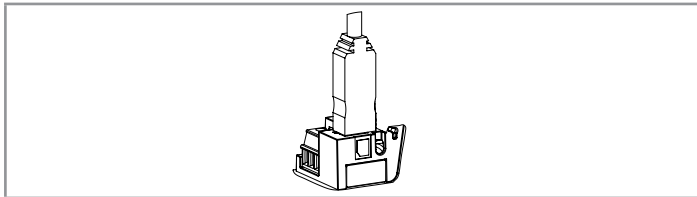

Fig. 5: bÜS stick, inserted in the related connector of the product

The Bürkert-Communicator software type 8920 enables for example:

- to set the parameters of the product, e.g. the basic settings for commissioning,
- to run the diagnostics, and e. g. read the error memories,
- to update the software,
- to adjust the user-defined calibration curve.

5.9 Replaceable configuration memory

NOTE!

If the configuration memory is defective or lost, buy a new configuration memory at your Bürkert sales office. See chap. [12.1 Electrical Accessories](#) and chap. [10.3 Replacing the configuration memory](#).

The product has a replaceable configuration memory, on which the product-specific data is stored.

The product is delivered with the configuration memory inserted.

The configuration memory enables the exchange of specific data with products having the same order code. For example, to transfer the data from a defective product to a new product.

The configuration memory holds, for example, the baud rate, the address and/or the designations of the measuring points of the product.

If, at start of the product, the inserted configuration memory contains product-specific data, the product adopts the data. And if there are no product-specific data on the configuration memory,

the product loads its own data onto the configuration memory.



A list of the stored data can be found in the Help for the Initiation file (download from www.burkert.com).

5.10 Operating principle of the MFC (Mass Flow Controller)

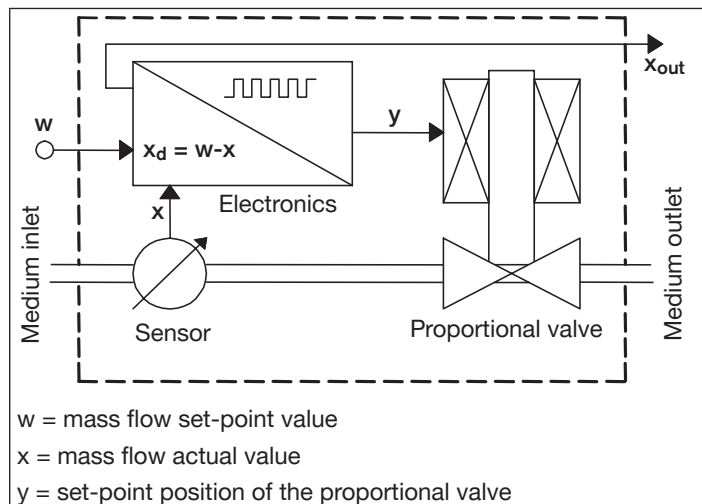

Fig. 6: Function diagram of the MFC (Mass Flow Controller)

5.11 Proportional valve of an MFC

The proportional valve used in an MFC is:

- either a direct-acting, normally-closed solenoid valve,
- or a direct-acting, normally-closed motor valve.

NOTE!

The sealing function of the proportional valve cannot be guaranteed for hard sealing materials.

When used within the specified pressure range, the proportional valve used in a mass flow controller (MFC) also provides the sealing function.

Exception:

If the seat seal is composed of a special, hard sealing material (e.g. PCTFE), as for nominal valve diameters of 0.05 mm and 0.1 mm, then the leakage rate of the proportional valve can differ from that of a product with a soft seat seal (e.g. FKM or EPDM).

The maximum leak rate in both cases is 1 Nml/min (air). A higher tightness is possible on request.

The nominal diameter of the solenoid valve is determined by the required nominal flow-rate Q_{nominal} , the pressure conditions in the process and the density of the operating medium.

→ Refer to the datasheet type 8745 to choose the correct nominal diameter for your application.

6 TECHNICAL DATA

6.1 Conformity

The product complies with the EU-directives according to the EU declaration of conformity (if applicable).

6.2 Standards

The applied standards, which verify conformity with the EU directives, can be found on the EU-type examination certificate and/or the EU declaration of conformity (if applicable).

6.3 Operating conditions



WARNING

Risk of injury from malfunction due to outdoor use!

- ▶ Do not use the product in outdoor areas.



WARNING

Risk of injury caused by pressure, medium escape!

Important product-specific data are indicated on the rating plate and calibration plate.

- ▶ Only use the product for the specified operating medium.
- ▶ Do not exceed the specified calibration pressure.

Ambient temperature	-10 °C...+50 °C ¹⁾
Medium temperature, MFM, MFC with solenoid valve	<ul style="list-style-type: none"> • -10 °C...+70 °C • -10 °C...+60 °C for oxygen
Medium temperature, MFC with motor valve	<ul style="list-style-type: none"> • 0 °C...+70 °C • 0 °C...+60 °C for oxygen
Ambient humidity	< 95 %, non-condensing
Protection class	IP20 ²⁾
Operating pressure, MFM, MFC with solenoid valve	Max. 10 bar (depending on the nominal diameter of the solenoid valve)
Operating pressure, MFC with motor valve	Max. 22 bar (depending on the nominal diameter of the motor valve)

Fig. 7: Operating conditions of the product

¹⁾ Only Ethernet products: the maximum temperature depends on the distance between 2 products. If the distance between 2 products is smaller than 30 mm, contact Bürkert.

²⁾ IP20 protection class has not been evaluated according to UL 61010 but determined by Bürkert.

6.4 Mechanical data

Dimensions, weight: see datasheet of the product.

Base block	Aluminium or stainless steel 1.4305
Housing	
• Ethernet version	• Polycarbonate (PC) and aluminium
• Analogue version	• Polycarbonate (PC)
Sealing material	See rating plate
Other materials of the proportional valve in contact with the medium	1.4310, 1.4113, 1.4305

Tab. 6: *Materials of the product*

6.5 Fluid data

Calibration medium	Operating gas or air
Mass flow range (reference to N ₂ (lN/min))	• 0.025...160 (if measurement range 1:50) • 0.01...160 (if measurement range 1:20)
Measurement accuracy	± 0.8% of the measured value ± 0.3% of the full scale (after 1 minute warm-up time)
Measurement range/control range	1:50* * Larger measuring range available on request. Repeat accuracy: ±0.1% of full scale deflection

Operating medium	See rating plate
Quality	Clean and dry. Quality classes according to DIN ISO 8573-1. See below.

For the required measurement and control precision and to meet the safety requirements, the gas or gas mixture must obey the following quality criteria given in standard ISO 8573-1 (Compressed Air - Part 1: Contaminants and purity classes):

Maximum particle size:	Class 2: 1 µm
Maximum particle density:	Class 2: 1 mg/m ³
Maximum dew point under pressure:	Class 4: 3 °C
Maximum oil concentration:	Class 1: 0.01 mg/m ³

For further information see ISO 8573-1.

Other dangerous gases are possible on request. Under normal operating conditions the product does not release any gas.

6.5.1 Pressure loss diagram (MFM)

Mass Flow Meters have a pressure drop depending on the flow rate, the pipe connection size and the density of the operating gas. The pressure loss can be determined with the following diagram.

The diagram shows an example of the compressed air loss for air flow.

The diagram shows the air pressure loss in the product for 3 different base bodies (up to 100 NI/min, range 100...500 NI/min, range 500...1500 NI/min) and 4 different connection sizes (1/4", 1/2", 3/4" and 3/8").

Example: For a flow rate of 1400 NI/min and a 1/2" pipe connection, the pressure loss Δp_{air} is 140 mbar (as given in Fig. 8).

For operating gases other than air, the pressure drop can be determined as follows:

1. Read the pressure drop Δp_{air} from the graph (approach $Q_{\text{gas}} = Q_{\text{air}}$).
2. Calculate the pressure loss Δp_{gas} with the following formula:

$$\Delta P_{\text{Gas}} = \Delta P_{\text{air}} \cdot \sqrt{\frac{\rho_N^{\text{Gas}}}{\rho_N^{\text{air}}}}$$

Under the root are the densities of the operating gas and of air in the normal state according to DIN 1343 ($P_N = 1013.25 \text{ mbar}$, $T_N = 273.15 \text{ K}$).

Example for the argon gas:

The pressure loss at a flow rate of 1400 NI/min and a 1/2" pipe connection is:

$$\Delta P_{\text{argon}} = 140 \text{ mbar} \cdot \sqrt{\frac{1,784}{1,294}} = 164,4 \text{ mbar}$$

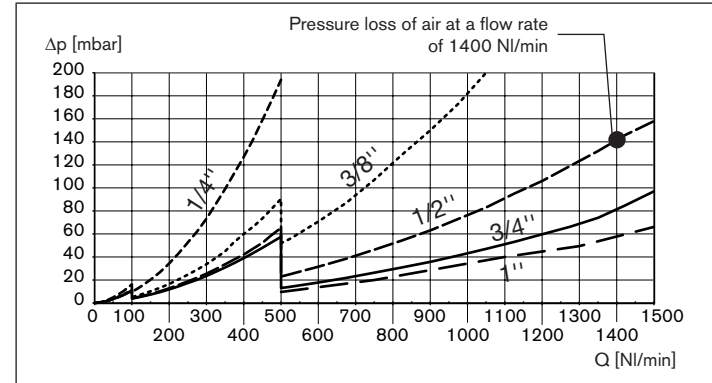

Fig. 8: Pressure loss diagram, for air, with a 250 µm mesh filter (MFM only)

6.6 Electrical data of an Ethernet version



WARNING

- ▶ For UL-certified components, only use limited power circuits of "NEC Class 2".

Operating voltage	<ul style="list-style-type: none"> ▪ MFC: 24 V DC $\pm 10\%$; residual ripple $< 2\%$ ▪ MFM: 24 V DC $\pm 10\%$
Maximum power consumption	Refer to the rating plate of the product or to the supplement type 8741/8742/8746 available at www.burkert.com
Fieldbus interface	PROFINET, EtherNet/IP, EtherCAT, Modbus TCP
LEDs	<ul style="list-style-type: none"> • 1 LED (according to NAMUR NE 107*) • 1 communication LED • 2 Link/Act LED (green) • 2 Link LEDs (yellow) • (MFC with motor valve) 1 LED for the status of the motor valve
Electrical connections	<ul style="list-style-type: none"> • 3-pin terminal strip, pitch 3,5 mm • 2 RJ45 sockets • bÜS service interface

* NAMUR recommendations (NE) 107: self-monitoring and diagnosis of field devices.
Standards committee for measurement and control technology (NAMUR) is an international association of users of automation systems for the process industry.

6.7 Electrical data of an analogue version



WARNING

- ▶ For UL-certified components, only use limited power circuits of "NEC Class 2".

Operating voltage	<ul style="list-style-type: none"> ▪ MFC: 24 V DC $\pm 10\%$ (15 V DC $\pm 10\%$ on request); residual ripple $< 2\%$ ▪ MFM: 24 V DC $\pm 10\%$ (15 V DC $\pm 10\%$ on request)
Maximum power consumption	Refer to the rating plate of the product or to the supplement type 8741/8742/8746 available at www.burkert.com
Electrical connections	<ul style="list-style-type: none"> • D-sub DE-9 plug or 6-pin terminal strip with a 5.0-mm pitch • bÜS service interface
Set-point analogue input	<ul style="list-style-type: none"> • 0/4...20 mA • Maximum input impedance: 200 Ω Resolution: 5 μA
	<ul style="list-style-type: none"> • 0...5/10 V • Minimum input impedance: 20 kΩ Resolution: 2,5 mV

Set-point analogue output	
• 0/4...20 mA	• Maximum loop impedance: 600 Ω at an operating voltage of 24 V DC (200 Ω at an operating voltage of 15 V DC); Resolution: 20 µA
• 0...5/10 V	• Maximum current: 20 mA Resolution: 10 mV
Digital input	Only for analogue versions with a D-sub DE-9 plug
• 0...0,2 V	• to activate level 1
• 1...4 V or open	• to activate level 2
• 5...28 V	• to activate level 3
Relay output	Only for analogue versions with a D-sub DE-9 plug Normally closed contact (break contact), free of potential
LED's	• 1 LED (according to NAMUR NE 107*) • (MFC with motor valve) 1 LED for the status of the motor valve

* NAMUR recommendations (NE) 107: self-monitoring and diagnosis of field devices.
Standards committee for measurement and control technology (NAMUR) is an international association of users of automation systems for the process industry.

6.8 Markings



WARNING

Risk of injury caused by pressure, medium escape!

Important product-specific data are indicated on the rating plate and calibration plate.

- ▶ Only use the product for the specified operating medium.
- ▶ Do not exceed the specified calibration pressure.

6.8.1 Calibration plate

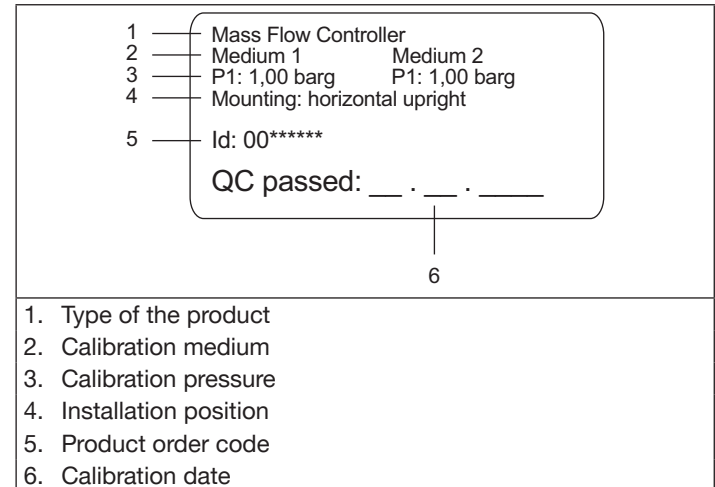
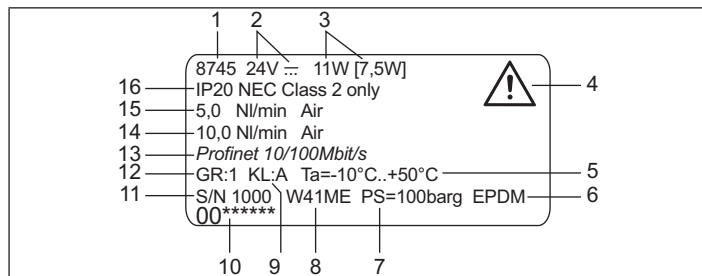

Fig. 9: Description of the calibration plate

6.8.2 Standard rating plate



1. Type of the product
2. Supply voltage, direct current
3. Consumption according to UL 61010-1 [solenoid valve: typical consumption ¹⁾; motor valve: power consumption ¹⁾ to hold the position of the valve]
4. Warning symbol: observe the Operating Instructions delivered with the product.
5. Ambient temperature
6. Sealing material
7. Burst pressure
8. Manufacturing code
9. Class of the valve (according to the DVGW ²⁾)

¹⁾ Conditions: ambient temperature 23 °C, nominal flow rate 100%, regulation for 30 minutes

²⁾ DVGW = Deutsches Verein des Gas- und Wasserfaches

10. Product order code
11. Serial number
12. Category of the product
13. Communication interface (Ethernet version) or input and output (analogue version)
14. Nominal flow rate (Qnominal), units and operating medium gas 2
15. Nominal flow rate (Qnominal), units and operating medium gas 1
16. Protection rating

Fig. 10: Description of the rating plate (example)

6.8.3 Additional markings

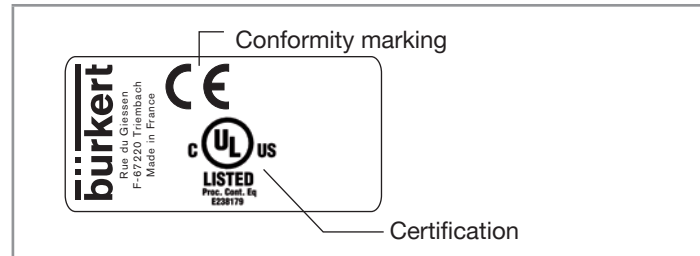

Fig. 11: Marking of the conformity and the certification



Find the description of the older markings on the product in the supplement at www.burkert.com



Fig. 12: Ethernet version: marking with the MAC address (example)

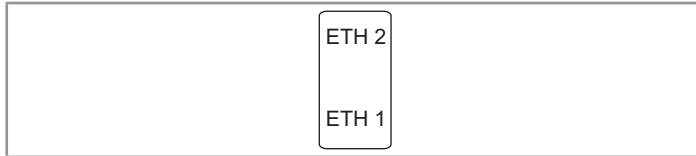

Fig. 13: Ethernet version: marking with the Ethernet ports

6.9 Communication interface: Industrial Ethernet

Additional supported features	DCP, VLAN priority tagging, Shared Device
Transmission speed	100 MBit/s
Data transport layer	Ethernet II, IEEE 802.3
IRT	not supported
MRP	MRP Client is supported
Minimum cycle time	1 millisecond
AR (Application Relations)	Simultaneous processing of up to 2 IO AR's, 1 Supervisor AR and 1 Supervisor-DA AR
PROFINET IO specification	V2.3
Topology recognition	LLDP, SNMP V1, MIB2, Physical Device Record Object

Tab. 7: PROFINET data

Address Conflict Detection (ACD)	supported
DHCP	supported
BOOTP	supported
CIP Reset services	Type 0 and 1 for the Identity object
Transmission speed	10 and 100 MBit/s
Duplex transmission	Half-duplex, duplex, auto-negotiation
Data transport layer	Ethernet II, IEEE 802.3
DLR (ring topology)	supported
MDI modes	MDI, MDI-X, Auto-MDIX
Predefined standard objects	<ul style="list-style-type: none"> • Identity (0x01) • Message Router (0x02) • Assembly (0x04) • Connection Manager (0x06) • DLR (0x47) • QoS (0x48) • TCP/IP Interface (0xF5) • Ethernet Link (0xF6)

Tab. 8: EtherNet/IP data

Transmission speed	10 and 100 MBit/s
Data transport layer	Ethernet II, IEEE 802.3
Modbus Function Codes	1, 2, 3, 4, 6, 15, 16, 23
Mode	Message Mode: Server

Tab. 9: Modbus TCP data

7 INSTALLATION

7.1 Safety instructions



DANGER

Danger due to high pressure in the installation/product.

- ▶ Before working on the installation or product, cut the pressure and vent and drain the pipes.

Risk of injury from electric shocks.

- ▶ Before working on the installation or product, switch off the power and ensure that it cannot be reactivated.
- ▶ Observe the applicable accident protection and safety regulations for electrical equipment.

Risk of injury from medium escape.

- ▶ Observe the applicable accident protection and safety regulations relating to the operating medium used.



WARNING

Danger of injury from improper installation!

- ▶ The installation must only be carried out by trained personnel using suitable tools.
- ▶ Secure the system against unintentional actuation.
- ▶ Ensure a controlled restart after installation.

Steps for installing the product:

1. Mechanical installation. Refer to chap. [7.4](#).
2. Fluid system installation. Refer to chap. [7.5](#).
3. Electrical installation. Refer to chap. [7.6](#).
4. If needed, set the Industrial Ethernet address. Refer to chap. [7.7](#).

7.2 Additional documentation

- Product-specific help in the Bürkert-Communicator software (refer to the related Operating Instructions).
- Device description file and object description for the type 8745 (download from www.burkert.com)
- Supplement for type 8741 / 8742 / 8746 (download from www.burkert.com)
- büS-driver for LabVIEW on request.

7.3 Recommendations before installation

→ Before installation of the fluid connections to the product, remove all dirt from the pipes and from the fluid carrying components of the installation.

NOTE!

Malfunction due to contamination.

- ▶ If a contaminated operating medium is used, install a filter (mesh size $\leq 25 \mu\text{m}$) upstream of the product to ensure problem-free functioning of the MFC. See chap. [6.5 Fluid data](#).

7.4 Mechanical installation



Vibrations have an unwanted effect on the proportional valve of the MFC.

- ▶ Avoid severe vibrations.

→ Observe the installation position given on the calibration plate or in the calibration protocol.

7.5 Fluid system installation



DANGER

Danger due to high pressure in the installation/product.

- ▶ Before working on the installation or product, cut the pressure and vent and drain the pipes.



WARNING

Danger due to leakage!

At low mass flows and high pressures, particular attention must be paid to the tightness of the system in order to prevent incorrect metering or leakage of the operating medium.

To ensure a secure seal

- ▶ Mount the pipe connections (for example compression fittings) without subjecting them to any stresses.
- ▶ Use compression fittings to ensure sealing of the system.
- ▶ Use pipes with a diameter adapted to the fluid connection of the product, and with a smooth surface.

For the connection to the process, the product is equipped with a threaded process connection plate according to DIN ISO 228/1.

→ If the pipe connections are not delivered with the product, choose pipe connections adapted to the fluid connection of the product. Compression fittings are available as accessories, see [Tab. 10](#).



The seal for each fluid connection must be ordered separately.

Product threaded connection in accordance with DIN ISO 228/1	Pipe diameter	Order code, stainless steel compression fitting	Order code of seal (1 piece)
G 1/4	6 mm	901 538	901 575
G 1/4	8 mm	901 540	
G 1/4	1/4"	901 551	901 579
G 1/4	3/8"	901 553	
G 3/8	8 mm	901 542	901 576
G 3/8	10 mm	901 544	
G 3/8	1/4 "	901 555	901 580
G 3/8	3/8 "	901 556	
G 1/2	10 mm	901 546	901 577
G 1/2	12 mm	901 548	
G 1/2	1/2 "	901 557	901 581
G 1/2	3/4 "	901 558	
G 3/4	12 mm	901 549	901 578
G 3/4	3/4 "	901 559	901 582

Tab. 10: Stainless steel compression fittings and seals

Procedure:

No inlet section is required.

The connection to the pipe is explained for one side of the product. The same procedure applies on the other side of the product. The procedure is given for the compression fittings available from Bürkert.

→ Cut the pipe squarely [1] and deburr [2].

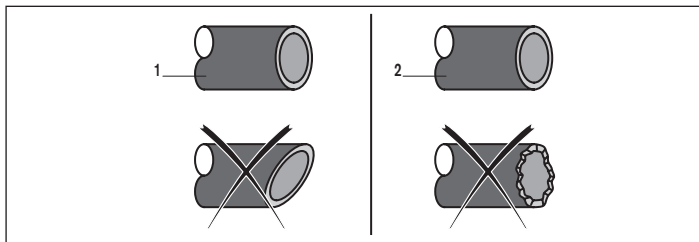

Fig. 14: Cutting the pipe and deburring

→ Remove the protective cap with which the threaded connection is closed.

→ Slide the union nut [A] and then the ferrule onto the pipe.

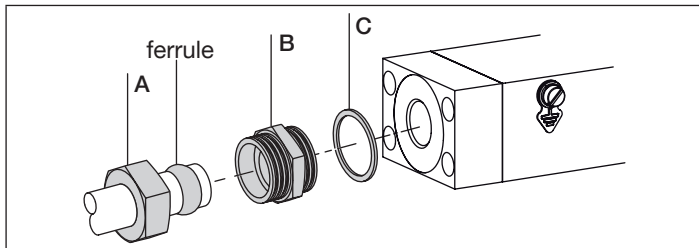

Fig. 15: Slide the union nut and the ferrule onto the pipe

→ Fix the sealing ring [C] and the connecting thread [B] to the product (tightening torque 25...28 N·m, i.e. 18,44...20,65 lbf·ft).

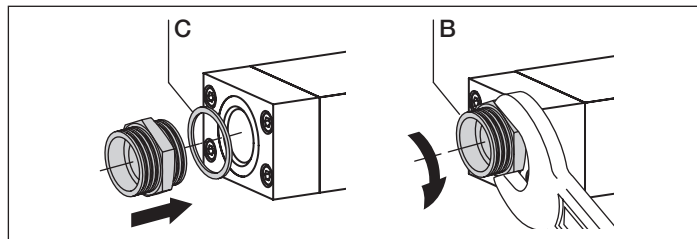

Fig. 16: Fix the sealing ring and screw on the connecting thread

→ Insert the pipe and tighten the union nut [A] by hand.

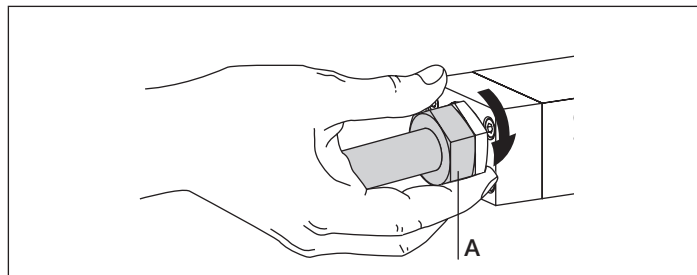

Fig. 17: Insert pipe and tighten the union nut

→ Tighten the lock nut with an open-end spanner so that the connection is leak tight (tightening torque 25...28 N·m, i.e. 18,44...20,65 lbf·ft).

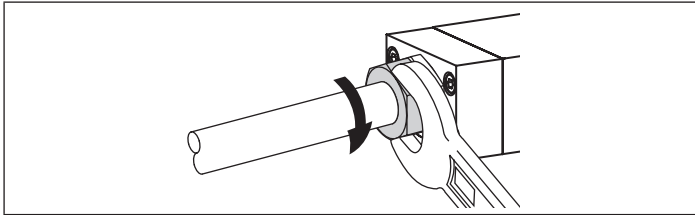

Fig. 18: Tighten the union nut

→ Do the fluid connection on the other side of the product in the same way.

7.6 Electrical installation



DANGER

Risk of injury from electric shocks.

- ▶ Before working on the installation or product, switch off the power and ensure that it cannot be reactivated.
- ▶ Observe the applicable accident protection and safety regulations for electrical equipment.

NOTE!

Requirements for the proper function of the product!

- ▶ Use a power supply with sufficient power.
- ▶ For an MFC pay attention to the maximum permissible residual ripple on the operating voltage (residual ripple < 2 %).
- ▶ For the connection of an Ethernet version, use only Industrial Ethernet shielded cables with a category CAT-5e or higher.
- ▶ For the connection of an analogue version, use only shielded cables.

7.6.1 Connecting the power supply and the functional earth (Ethernet version)

3-pin terminal strip	Pin	Pin assignment
	1	FE (functional earth)
	2	DGND
	3	+24 V

Fig. 19: Terminal assignment of the 3-pin terminal strip

- Open the cover of the product.
- Connect the conductors according to [Fig. 19](#).
- Earth the product as shown in chap. [7.6.5](#).
- Tighten the conductors at a torque between 0,22...0,25 N·m, i.e. 0,16...0,18 lbf·ft.

7.6.2 Connecting the Industrial Ethernet (only Ethernet version)

! On an Industrial Ethernet version, the cable shield is connected by the housing of the cable plug.

Both RJ45 sockets have the same pin assignment.

RJ45	Pin	Pin assignment
	1	TX+
	2	TX-
	3	RX+
	4	N. C.
	5	N. C.
	6	RX-
	7	N. C.
	8	N. C.
Housing	FE	

Fig. 20: Pin assignment of an RJ45 socket

- If a protocol other than EtherCAT is used, plug an Ethernet cable in one or both sockets.
- If the EtherCAT protocol is used, plug the incoming Ethernet cable (coming from the PLC) into the socket marked ETH1 and plug the outgoing Ethernet cable into the socket marked ETH2.

7.6.3 Connecting an analogue version with a D-sub DE-9 plug

! On an analogue version with a D-sub DE-9 plug, the cable shield is connected by the housing of the cable plug.

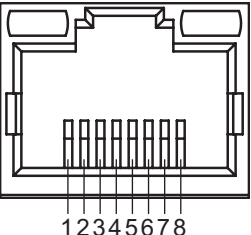
9-pin D-sub DE-9 plug	Pin	Pin assignment
	1	Digital input - Reference contact is pin 2 GND
	2	GND
	3	+24 V DC
	4	Relay - Normally closed contact (Break contact)
	5	Relay - Reference contact
	6	Set-point input +
	7	Set-point input GND
	8	Actual value output +
	9	Actual value output GND
Housing	FE	

Fig. 21: Pin assignment of the D-sub DE-9 plug, analogue version

- Insert the D-sub DE-9 cable socket on the plug.
- Tighten the screws at a torque between 0,5...0,6 N·m, i.e. 0,37...0,44 lbf·ft.
- Earth the product as shown in chap. 7.6.5.

7.6.4 Connecting an analogue version with a 6-pin terminal strip

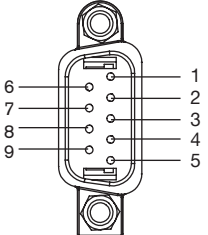

For the proper function of the product attach the cable shield to the product.

→ Connect a conductor of the cable shield to the M4 screw (see Fig. 23, chap. 7.6.5), either directly or with a cable lug.

6-pin terminal strip	Pin	Pin assignment
1	1	+24 V DC
2	2	GND
3	3	Set-point analogue input +
4	4	Set-point analogue input GND
5	5	Actual value analogue output +
6	6	Actual value analogue output GND

Fig. 22: Pin assignment of the 6-pin terminal strip, analogue version

→ Connect the conductors according to Fig. 22.

→ Tighten the screws at a torque between 0,5...0,6 N·m, i.e. 0,37...0,44 lbf·ft.

→ Earth the product as shown in chap. 7.6.5.

7.6.5 Connecting the functional earth



WARNING

Risk of ignition and fire due to electrostatic discharge!

An electrostatic discharge of the product can ignite combustible gas vapours.

- ▶ Connect the housing to the functional earth (FE) with a short cable with a large cross-section to avoid a build up of electrostatic charge.



WARNING

If the functional earth (FE) is not attached, the requirements of the EMC directive are not met.

- ▶ Connect the housing to the functional earth (FE) with a short cable with a large cross-section.

→ Earth the product:

- either with the M4 screw (torque between 1,8...2 N·m, i.e. 1,33...1,47 lbf·ft);
- or, on an Ethernet version only, with terminal 1 of the 3-pin terminal strip (torque between 0,22...0,25 N·m, i.e. 0,16...0,18 lbf·ft).

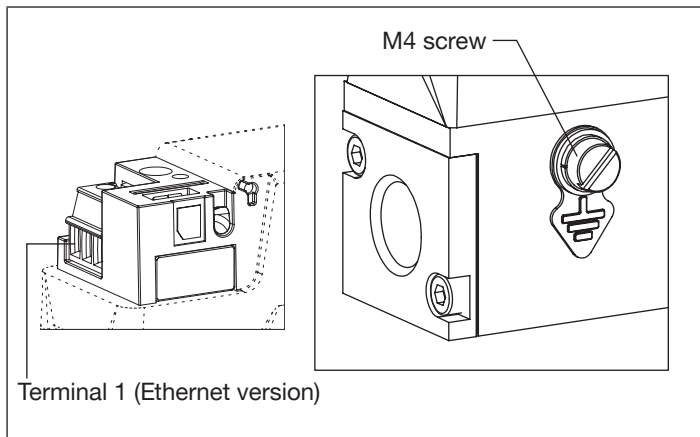

Fig. 23: Connection options for functional earthing FE

7.7 Setting the Industrial Ethernet address (only Ethernet version)

- To set the fieldbus address:
 - use the Bürkert-Communicator software.
 - Or use the man-machine interface of the PLC the product is connected to.
- If the address is changed and to avoid malfunction of the product, restart the product by turning off and on the power supply.

8 COMMISSIONING

8.1 Safety instructions



WARNING

Danger of injury from improper operation!

Improper operation can lead to injuries and damage to the product and its environment.

- ▶ Before commissioning, make sure that the operating personnel are familiar with, and fully understand the content of these Operating Instructions.
- ▶ The safety information and the intended use must be observed.
- ▶ Only properly trained personnel may commission the installation/product.

Steps for commissioning:

1. Pressurise the pipes with operating medium
2. Flush the pipes with operating medium at the calibration pressure and then vent them completely.
3. Energize the product.
4. Run the Autotune function.
Only required if the operating medium is not the calibration medium or if the pressure conditions have changed. (See chap. [9.4 Optimising the control parameters \(MFC\)](#)).
5. Regular operation.

9 OPERATION

9.1 Safety instructions



WARNING

Danger due to improper operation!

Improper operation can lead to injuries and damage to the product and its environment.

- ▶ The operating personnel must have read and understood the content of this manual.
- ▶ The safety information and the intended use must be observed.
- ▶ Only properly trained personnel may operate the installation/product.
- ▶ Only properly trained personnel may change parameters with the help of the Bürkert-Communicator software.

9.2 Changing the fieldbus address (only Ethernet version)

→ Refer to chap. [7.7 Setting the Industrial Ethernet address \(only Ethernet version\)](#).

9.3 Normal control mode (MFC)

9.3.1 Ethernet version

After applying the operating voltage, the product enters a short initialisation phase and then switches to the **Automatic** operating mode.

- To change the control mode, i. e. to change the source for the set-point values, see chap. [9.8](#).
- To change the control parameters, use the Bürkert-Communicator software.

9.3.2 Analogue version

After applying the operating voltage, the product enters a short initialisation phase and then switches to the **Analog set-point value** operating mode.

The set-point value w ([Fig. 6](#) chap. [5.10](#)) is transmitted over the set-point analogue input.

The actual value of the flow rate is transmitted over the analogue output according to the ranges given in [Tab. 11](#).

Analogue output range	Minimum value of the input and output ranges	Maximum value of the input and output ranges
4...20 mA	4 mA, $w = 0\%$	20 mA, $w = 100\%$
0...20 mA	0 mA, $w = 0\%$	
0...5 V	0 V, $w = 0\%$	5 V, $w = 100\%$
0...10 V		10 V, $w = 100\%$

Tab. 11: Analogue input and output ranges

- To change the control mode, i. e. to change the source for the set-point values, see chap. 9.8.
- To change the control parameters, use the Bürkert-Communicator software.

9.4 Optimising the control parameters (MFC)

The product is calibrated at the factory with the calibration medium under the pressure conditions that are specified on the calibration protocol. If the operating conditions change, the Autotune function must be run. The function Autotune optimises the product for the new operating conditions.

When the Autotune is running:

- Do not interrupt the power supply to the MFC.
- Keep the supply pressure constant.



WARNING

Danger from flowing gas!

While the Autotune function is running, the gas flow can be higher than the nominal flow.

- ▶ Before running the Autotune function, make sure no danger can occur if the gas flow increases.

- Trigger the Autotune function:
 - via the fieldbus (Ethernet version),
 - via the digital input (analogue version),
 - or with the Bürkert-Communicator software.

- ✓ The Autotune runs and the product status LED changes its colour: see chap. 11.1 [Display of the product status](#).
- ✓ The flow rate control of the MFC is stopped.
- ✓ When the function is completed, the product returns to its previous operating mode.
- ✓ After successful running of the function, the optimised control parameters are transferred to the hard memory of the product.

9.5 Digital input (analogue version with a D-sub DE-9 plug)

The digital input has 3 switching levels to remotely trigger a function. The following functions are available (among others):

- (Only MFC) Start the function autotune (default setting),
- Reset the totalizer for the active gas,
- Select which gas is active among 3 gases,
- (Only MFC) Trigger the remote control of the actuator or trigger the control of the actuator by the product.

Depending on the function, use the switching levels as shown in [Tab. 12](#).

- To choose the function to be remotely triggered over the digital input, use the Bürkert-Communicator software. Only one of the available functions can be associated to the digital input.

Function	Associated switching level		
	Level 1	Level 2	Level 3
Start autotune (default setting)	If activated, triggers the function	Not used	Not used
Reset totalizer	If activated, triggers the function	Not used	Not used
Gas selection	If activated, changes to gas number 2	If activated, changes to gas number 1	If activated, changes to gas number 3
Actuator control	If activated, triggers the closing of the actuator	If activated, the product is in the normal control mode	If activated, triggers the opening of the actuator

Tab. 12: Switching levels used depending on the function

→ To trigger the function, apply the values given in [Tab. 13](#) to the digital input.

Level	Voltage value to be applied to the digital input to trigger the chosen function
Level 1	Shortcut with GND (pin 2)
Level 2	1...4 V DC (as an alternative, not connected)
Level 3	5...28 V DC

Tab. 13: Voltage values associated to the switching levels

9.6 Relay output (analogue version with a D-sub DE-9 plug)

The switching of the relay can show either that:

- (Only MFC) The set-point value cannot be reached (default setting).
- (Only MFC) The product is doing an Autotune.
- (Only MFC) The **Set-point value source** has changed.
- A warning message has been generated (for example if the supply voltage is too high).
- A failure message has been generated (for example a sensor failure).

→ To change the setting, use the Bürkert-Communicator software.

9.7 Zero point shut-off (MFC)

A zero point shut-off is included to ensure the sealing function of the integrated valve. This is activated if the following conditions occur simultaneously.

1. Set-point value < 2 % of nominal flow rate $Q_{nominal}$ (with measuring range 1:50)
2. Actual value < 2 % of nominal flow rate $Q_{nominal}$ (with measuring range 1:50)



If the zero point shut-off is active, the PWM signal is set to 0 % so that the valve is completely closed.

9.8 Specifying the source giving the set-point value (MFC)

The process set-point value can be set by different sources. You can choose which source is active at a time. The source for the set-point value can be changed during operation. The parameter **Set-point value source** allows to change the source:

- via a setting in the Bürkert-Communicator software.
- or, for an Ethernet version only, by changing a device description object.



The setting of the parameter **Set-point value source** is kept after a restart, except if the product performs an **Analyze system** function.

The possible settings for the **Set-point value source** are:

- **Automatic**: (only Ethernet versions) the set-point value is set via the fieldbus. If different fieldbus participants simultaneously specify a set-point value for the product, it is always the last set value that is used.
- **Analog set-point value**: (only analogue versions) the set-point value is set via the analogue input.
- **Manual set-point value**: to manually give in a set-point value for testing purposes or to make sure that the set-point value is not overwritten by other fieldbus participants.
- **Stored set-point value**: to use a fixed set-point value. The fixed set-point value remains active even if the product is restarted.

- **Open-loop control mode**: to directly set the duty cycle to the proportional valve. When this function is activated the current duty cycle is used. Following a restart of the product, the duty cycle is set to zero.
- **Analyze system**: the product operates under the normal conditions of the **Automatic** operating mode according to a predefined chronological sequence with set-point values. Use the resulting diagram in combination with the graphical representation of process values to analyse the system with the Bürkert-Communicator software.

9.9 User-defined calibration

At delivery the product is calibrated by the manufacturer.

With the Bürkert-Communicator software, you can define a calibration procedure with up to 32 calibration points.



The user-defined calibration procedure is described in the product-specific Help of the Bürkert-Communicator software (refer to the related Operating Instructions).

9.10 Flush mode (MFC, Ethernet version only)

NOTE!

If the integrated valve is fully open, the internal product temperature increases. If the internal product temperature increases, the product can be damaged.

- Do not let the valve fully open for more than 10 minutes.

To open the valve completely:

- send an acyclic command to the product,
- or send a cyclic command with the double nominal flow rate.

9.11 Set-point values without communication (MFC, Ethernet version only)

The function makes it possible to specify the set-point values of an MFC even if the communication with the external set-point value provider (e.g. a PLC) is broken. If the function is used, the set-point is kept constant.



By using this function, the medium can continue to flow even if the communication is broken.

- ▶ Make sure the process is safe when you use this function.

- To use this function, refer to the related procedure in the product-specific help in the Bürkert-Communicator software type 8920 (refer to the related Operating Instructions) or in the documentation of the initiation files (download at www.burkert.com).

10 MAINTENANCE

The product is maintenance-free, if no heavily contaminated media are used and if it is operated according to the Operating instructions.

10.1 Maintenance for operation with heavily contaminated media



DANGER

Danger due to high pressure in the installation/product.

- ▶ Before working on the installation or product, cut the pressure and vent and drain the pipes.

Risk of injury from electric shocks.

- ▶ Before working on the installation or product, switch off the power and ensure that it cannot be reactivated.
- ▶ Observe the applicable accident protection and safety regulations for electrical equipment.



WARNING

Danger of injury from improper maintenance work!

- ▶ Maintenance must only be performed by trained personnel using suitable tools.
- ▶ Secure the system against unintentional actuation.
- ▶ Ensure a controlled restart after maintenance.

! WARNING

Risk of injury from malfunction and failure by opening the housing!

There are sensitive parts inside the product to control the flow and for measurement of the flow rate.

- ▶ Do not open the product housing.
- ▶ Only the cleaning and maintenance work described in this manual may be carried out on the product.
- ▶ Further work and calibration may only be performed by the manufacturer.

If a heavily contaminated operating medium is used:

- Regularly inspect the contamination of the stainless steel mesh filter [5] (see Fig. 24).
- Clean the stainless steel mesh filter when required, as described below.

10.1.1 Cleaning the stainless steel mesh filter

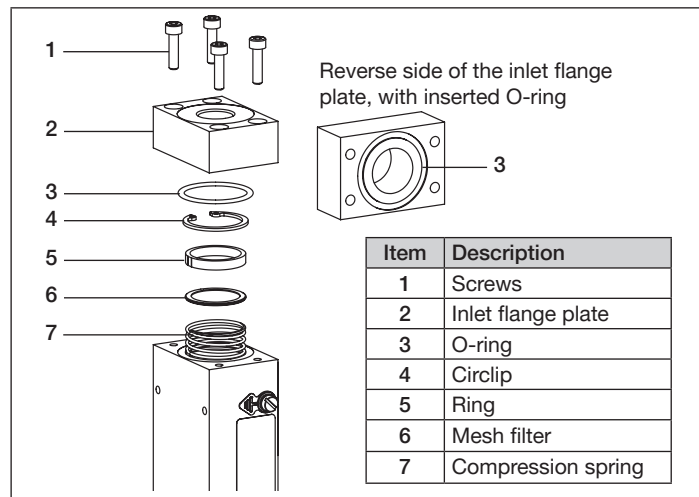

Fig. 24: Cleaning the stainless steel mesh filter

- Position the product upright with the fluid inlet at the top.
- Remove the inlet flange plate [2] by loosening the 4 screws [1] (see Fig. 24).
- Leave the O-ring [3] in the groove on the rear side of the inlet flange plate.
- Remove the circlip [4] using a pair of circlip pliers.
- ⚠ After the circlip is removed, the inlet filter [6] and the ring [5] are pushed out by an internal tensioned compression

spring.

- Clean the stainless steel mesh filter [6].
 - ⚠ Do not clean with tap water!
Clean with acetone, isopropanol or compressed air.
- Dry the stainless steel mesh filter [6] after cleaning.
- Push the compression spring [7] together with the inlet filter [6] back into the base block and secure them with the circlip [4].
 - ⚠ Before screwing back on the inlet flange plate, make sure that the O-ring [3] is correctly positioned in the inlet flange plate groove.
- Screw on the inlet flange plate [2].

10.2 Cleaning and recalibration at the factory

If the sensor is contaminated or damaged by operation, it may be that the signal for the mass flow rate no longer corresponds to the actual mass flow rate.

In this case the sensor must be replaced and recalibrated by the manufacturer.

10.3 Replacing the configuration memory

- To remove the configuration memory from the product, slightly push it to the stop in the product by using tweezers and release. The configuration memory comes out.

- Pay attention to the direction of insertion: see Fig. 25.

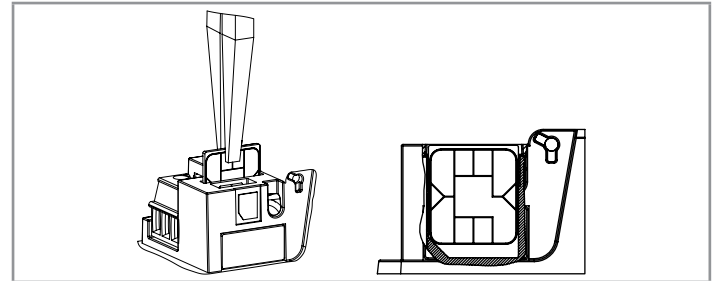

Fig. 25: Insertion direction for the configuration memory

- To set the configuration memory back in the product, push it to the stop (you can hear a locking noise). If the configuration memory comes out, the locking failed.

11 PRODUCT STATUS/TROUBLESHOOTING

11.1 Display of the product status

The product has an LED to display the product status, the colour and status change according to Namur NE 107.

If more than one product status exists simultaneously, the product status with the highest priority is displayed.

LED according to NE 107	Description	What to do?
OFF	The product is not energized.	Energize the product.
Flashing (any colour)	Product is selected using the Bürkert-Communicator software.	After 10 seconds, the product automatically returns to the previous status.
Green	The product is energized.	The product is in Automatic or Stored set-point value operating mode (see chap. 9.8.)
Red	Defective sensor.	Maintenance is needed – Contact the manufacturer.
	Defective memory.	
	Defective product.	
	Incorrect Autotune. Autotune aborted.	Do the Autotune again.
	Supply voltage out of the error range, potential destruction of the product.	Operate the product within the specifications.
(Only Ethernet version) No proper connection to the PLC	Check the wiring. Check the status of the PLC. If the EtherCAT protocol is used, make sure the incoming cable (reception from the PLC) is inserted in the ETH1 port and the outgoing cable is inserted in the ETH2 port.	
Orange	Autotune in progress	-
	Calibration in progress	-

LED according to NE 107	Description	What to do?
Orange	Control loop disabled, direct specification of the set-point position to the valve.	-
	(Only Ethernet version) PROFINET: PLC is in Stop mode	
	Manual set-point value or Open-loop control as set-point value source.	-
	Analyze system function active	-
Yellow	Medium temperature, product temperature or supply voltage out of specification, potential destruction of the sensor or product.	Operate the product within the specifications.
	The set-point position for the proportional valve has (almost) reached 100%. The set-point value cannot be attained.	Increase the operating pressure (observe the maximum permissible supply pressure). Check the pressure drop in the pipe and reduce it if necessary. Check the dimensions of the installation. Check the filters installed in the pipe and clean them if necessary.
	(Only Ethernet version) A change of the Ethernet protocol is in progress.	Wait until the change of protocol is completed. It can take up to 1 minute.
Blue	Memory error. Error detected in the calibration curve.	Maintenance is needed – Contact the manufacturer.

Tab. 14: Measures to take depending on the color of the product status LED

11.2 Troubleshooting

Problem	Possible cause	What to do?
The Namur LED goes out periodically	The power supply is intermittently dropping - the product therefore performs a reset.	Use a power supply with sufficient power output.
	The voltage drop in the connecting cable is too large.	Increase the cross-section of the cable. Reduce the cable length.

Problem	Possible cause	What to do?
The replacement product adopts none of the values on the configuration memory from the defective product	The order code of the replacement product differs from that of the defective product.	Values can only be transferred between products with the same order code.
	Configuration memory is defective - Product could not write any values to the configuration memory.	Replace the configuration memory (see accessories) and search again for the settings of the defective product to transfer to the card (see chap. 10.3).
The replacement product does not adopt all of the values on the configuration memory from the defective product	The product description of the replacement product differs from that of the defective product.	Only the existing values of the defective product can be adopted by the replacement product. The new values of the replacement product must be configured using the Bürkert-Communicator software.
No mass flow rate	The set-point value is below the zero-point shut-off limit.	Increase the set-point value until it is higher than 2% of the nominal flow rate.
	The product is not in the normal control mode. See chap. 9.3.	Check if the product is running one of the functions described in chap. 9.8.
	The pipes are too large or not yet fully vented.	Vent the pipes. Change the pipe diameter.
Unstable measured value	The functional earth (FE) is not properly connected.	Connect the functional earth with the shortest possible cable (cross-section at least 2.5 mm ²).
	The controller must compensate for irregularities in an unstable pressure supply caused, for example, by pumps.	Install a suitable pressure regulator in front of the product. Install a buffer tank to absorb the pressure fluctuations.
	The residual ripple on the voltage supply is too high.	Use a suitable supply voltage (See technical data).
Set-point value at 0 % but operating medium still flows	The operating pressure is above the tight sealing pressure of the proportional valve.	Reduce the operating pressure. To eliminate the defect, return the product to the manufacturer.

Problem	Possible cause	What to do?
Set-point value at 0 %, valve is closed, no mass flow, but a non-zero mass flow rate is measured	The installation position of the product is incorrect.	Install the product in the position indicated on the calibration plate or in the calibration protocol and run the Autotune function to adapt to the operating conditions.
	The operating medium is different from the medium specified during the calibration.	Use the specified operating medium or send the product to the manufacturer for calibration with the new operating medium.
Set-point value is not reached	The mesh filter is clogged.	Clean or replace the mesh filter.
	The inlet pressure is too low.	Increase the inlet pressure to the calibration pressure value.
	The outlet pressure is too high.	Check whether the fluid connection pipes after the product are dirty and clean if necessary.

Tab. 15: Troubleshooting

11.3 Troubleshooting for the motor valve

Problem	Possible cause	Do the following
LED flashing and red / LED lit and red	Temperature too high	→ Respect the maximum ambient temperature and medium temperature. → After the error has been removed, restart the device (deenergize the device) to turn off the red blinking LED.
	Cable break	→ Check if there are loose connections on the cable between the MFC and the motor valve.
Motor is humming unusually	Gears or motor blocked	→ Send the device back to the manufacturer for repair.

Tab. 16: Troubleshooting for the motor valve

12 ACCESSORIES / SPARE PARTS



CAUTION

Danger of injury and material damage due to unsuitable parts!

Incorrect accessories and unsuitable replacement parts can cause injuries and damage to the product and its environment.

► Only use original accessories and spare parts from Bürkert.

12.1 Electrical Accessories

Item	Order code
büS stick set (including power supply)	772426
büS stick set (without power supply)	772551
Configuration memory	On request

Tab. 17: *Electrical accessories (for further accessories, see the product datasheet)*

12.2 Compression fittings

The following compression fittings are available from Bürkert for the connection of the product to the pipe.

Compression fittings are suited for many applications, however alternative fittings can also be used.



The seal for each threaded connection must be ordered separately.

Product threaded connection in accordance with DIN ISO 228/1	Pipe diameter	Order code, stainless steel compression fitting	Order code of seal (1 piece)
G 1/4	6 mm	901 538	901 575
G 1/4	8 mm	901 540	
G 1/4	1/4"	901 551	901 579
G 1/4	3/8"	901 553	
G 3/8	8 mm	901 542	901 576
G 3/8	10 mm	901 544	
G 3/8	1/4 "	901 555	901 580
G 3/8	3/8 "	901 556	
G 1/2	10 mm	901 546	901 577
G 1/2	12 mm	901 548	
G 1/2	1/2 "	901 557	901 581
G 1/2	3/4 "	901 558	
G 3/4	12 mm	901 549	901 578
G 3/4	3/4 "	901 559	901 582

Tab. 18: *Stainless steel compression fittings and seals*

13 DECOMMISSIONING

13.1 Safety instructions



DANGER

Danger due to high pressure in the installation/product.

- ▶ Before working on the installation or product, cut the pressure and vent and drain the pipes.

Risk of injury from electric shocks.

- ▶ Before working on the installation or product, switch off the power and ensure that it cannot be reactivated.
- ▶ Observe the applicable accident protection and safety regulations for electrical equipment.



WARNING

Risk of injury from improper dismantling!

- ▶ Dismantling must only be performed by trained personnel using suitable tools.

Risk of injury from hazardous media.

- ▶ Before disconnecting pipes or valves, flush out hazardous media, release pressure in the pipes and drain.
- ▶ Observe the applicable accident protection and safety regulations relating to the operating medium used.

13.2 Dismantling the product

- Relieve the operating medium pressure in the system.
- Flush the product with a neutral medium (e.g. nitrogen)
- Relieve the flushing medium pressure in the system.
- Switch off the power.
- Remove the electrical wiring.
- Disconnect the fluid connections.
- Remove the product.

14 TRANSPORT

NOTE!

Transport damage!

Damage can be caused to insufficiently protected products in transport.

- Remove cables, connectors, separate filters and mounting hardware.
- Clean and vent contaminated products.
- Close the fluid connections with protective caps to prevent damage and protect the sealing.
- Pack the product in two suitable zip lock bags, to avoid any contamination during the transport.
- Transport the product in an impact-resistant package, protected from moisture and dirt.
- Avoid storage above or below the recommended storage temperature.

15 STORAGE, DISPOSAL

NOTE!

Incorrect storage can cause damage to the product.

- Close fluid connections with protective caps.
- Store the product dry and dust-free in sealed zip lock bags!
- Storage temperature $-10...+70$ °C.

Environmental damage due to parts contaminated by media.

- Dispose of the product and its packaging in an environmentally friendly manner!
- Comply with applicable environmental and disposal regulations.

16 RETURNING THE PRODUCT



No work or tests will be carried out on the product until a valid Contamination Declaration has been received.

The Contamination Declaration with order code 806 075 can be downloaded from our homepage or requested from your local Bürkert sales office.

www.burkert.com → [Service & Support](#) → [Service / Maintenance / Commissioning](#) → [Declaration of contamination](#)

To return a product already in use, a returns number is required.

To return a product that has already been used to Bürkert, proceed as follows:

- Fill out the Contamination Declaration.
- Send the declaration to the address indicated on the form:
You will then receive a Returns Number by fax or post from Bürkert.
- Pack the product as described in chap. 14.
- Return the product to Bürkert with the Contamination Declaration, quoting the returns number.

Address:

Bürkert Fluid Control Systems
Corporate Quality / Complaint Management
Chr.-Bürkert-Str. 13-17
D-74653 Ingelfingen
Tel. + 49 (0) 7940 - 10 91 599
Fax + 49 (0) 7940 - 10 91 490
E-Mail: service.international@burkert.com

www.burkert.com