

Type 8006 / 8702

MFM, Mass Flow Meter IP65

Type 8626 / 8712

MFC, Mass Flow Controller IP65



Operating Instructions

Bedienungsanleitung

Manuel d'utilisation

We reserve the right to make technical changes without notice.
Technische Änderungen vorbehalten.
Sous réserve de modifications techniques.

© Bürkert SAS, 2013-2015

Operating Instructions 1505/03_EU-ML 00563581

1. ABOUT THIS MANUAL.....	4	7.3. Description of the MFM / MFC	19
1.1. Symbols used	4	7.4. Sequence of the steps to be performed.....	20
1.2. Definition of the word "device"	4	7.5. Setting the parameters.....	20
2. INTENDED USE.....	5	7.6. Mechanical installation.....	23
3. BASIC SAFETY INSTRUCTIONS.....	5	7.7. Fluid installation.....	23
4. GENERAL INFORMATION	7	7.8. Electrical installation.....	25
4.1. Manufacturer's address and international contacts	7	8. OPERATION AND FUNCTION.....	26
4.2. Warranty conditions	7	8.1. Safety instructions.....	26
4.3. Information on the Internet.....	7	8.2. Operation.....	26
5. DESCRIPTION OF THE SYSTEM	7	8.3. MFC operating modes.....	32
5.1. General description	7	9. MAINTENANCE, TROUBLESHOOTING	36
5.2. Operation of an MFM or MFC sensor.....	8	9.1. Safety instructions.....	36
5.3. Detailed operation of an MFC	8	9.2. Maintenance.....	36
6. TECHNICAL DATA.....	11	9.3. Troubleshooting.....	38
6.1. Markings on the device.....	11	10. ACCESSORIES / SPARE PARTS	41
6.2. Conditions of use.....	12	10.1. Accessories	41
6.3. Compliance to standards and directives.....	13	10.2. Spare part.....	44
6.4. Mechanical data	13	11. SHUTDOWN.....	44
6.5. Fluidic data	13	11.1. Safety instructions	44
6.6. Electrical data, devices with an 8 pin M16 female fixed connector.....	16	11.2. Dismounting of the MFM / MFC	45
6.7. Electrical data, devices with a 9 pin Sub-D male fixed connector, with RS485 interface.....	17	12. PACKAGING, STORAGE, TRANSPORT.....	45
7. INSTALLATION AND COMMISSIONING.....	18	12.1. Packaging, Transport.....	45
7.1. Safety instructions.....	18	12.2. Storage.....	45
7.2. Prior to installation	18	13. RETURNING THE DEVICE.....	46
		14. DISPOSAL OF THE PRODUCT	46

1. ABOUT THIS MANUAL

This manual describes the entire life cycle of the device. Please keep this manual in a safe place, accessible to all users and any new owners.

This manual contains important safety information.

Failure to comply with these instructions can lead to hazardous situations.

- This manual must be read and understood.

1.1. Symbols used



DANGER

Warns against an imminent danger.

- Failure to observe this warning can result in death or in serious injury.



WARNING

Warns against a potentially dangerous situation.

- Failure to observe this warning can result in serious injury or even death.



ATTENTION

Warns against a possible risk.

- Failure to observe this warning can result in substantial or minor injuries.

NOTE

Warns against material damage.

- Failure to observe this warning may result in damage to the device or system.



Indicates additional information, advice or important recommendations.



Refers to information contained in this manual or in other documents.

→ Indicates a procedure to be carried out.

1.2. Definition of the word "device"

The word "device" used within this manual refers to a Mass Flow Meter (MFM) type 8006 or 8702, or a Mass Flow Controller (MFC) type 8626 or 8712.

2. INTENDED USE

Nonconforming use of the MFM / MFC types 8006, 8702 / 8626, 8712 may pose a danger to people, nearby equipment and the environment.

- Mass flow meter types 8006, 8702 are designed exclusively for measuring the mass flow rate of clean, dry gases.
- Mass flow controller types 8626, 8712 are designed for controlling the mass flow rate of clean, dry gases.
- Only use the fluids stated on the name plate and the calibration protocol.
- Protect this device against electromagnetic interference, ultraviolet rays and, when installed outdoors, the effects of the climatic conditions.
- This device must be used in compliance with the specifications and commissioning and use conditions specified in the contractual documents and in the user manual.
- Requirements for the safe and proper operation of the device are proper transport, storage and installation, as well as careful operation and maintenance.
- Only use the device as intended.
- Observe any existing restrictions when the device is exported.

3. BASIC SAFETY INSTRUCTIONS

These safety instructions do not take into account:

- any contingencies or occurrences that may arise during installation, use and maintenance of the devices.
- the local safety regulations, which the operating company is responsible for ensuring the staff in charge of installation and maintenance adhere to.



Danger from the heated surfaces when used for prolonged periods.

- The device must be kept away from any highly flammable materials or fluids.
- Wear protective gloves to handle the device.

Danger due to high pressure in the installation.

- Shut off the gas flow, relief the pressure and drain the pipe before loosening the process connections.

Danger due to electrical voltage.

- Shut down and isolate the electrical power supply before carrying out work on the system.
- Observe all applicable accident protection and safety regulations for electrical equipment.

Danger from the outflow of operating fluid

Respect the prevailing regulations on accident prevention and safety relating to the operating fluids used.

Various dangerous situations

To avoid injury take care:

- to prevent unintentionally switching on the power supply.
- to ensure that installation and maintenance work is carried out by qualified, authorized personnel in possession of the appropriate tools,
- to keep the device away from any highly flammable materials or fluids and avoid any contact with bare hands,
- to guarantee a defined or controlled restarting of the process, after an interruption to the power supply or medium supply,
- to use the device only if in perfect working order and in compliance with the instructions provided in the instruction manual,
- to observe best industry practice for the installation and use of these devices,
- not to use MFM / MFC types 8006, 8702 / 8626, 8712 for controlling and/or measuring the flow rate of fluids which contain particles (particle size > 25 µm),
- not to operate the device without the stainless steel mesh filter disc installed at the factory,
- not to operate the device in a mounting position which deviates from the calibration conditions,
- not to operate the device with higher pressures than the specified tightness pressure (MFC) respectively calibration pressure (MFM),

- not to subject the device to mechanical loads (e.g. by placing objects on top of it or by using it as a step).
- not to make any external modifications to the device. Do not paint or varnish any part of the device. Do not feed any other fluids into the system other than the designated operating fluid indicated on the device name plate. Exception: agent for cleaning and decontaminating the device (see also section „9.2.1“). In doing so, observe the compatibility of the materials used for the device. You will find a chemical compatibility chart on our website, under:

www.burkert.com → [Documentation](#) → [Brochures](#) → [Chemical Resistance Chart](#)

If in doubt, contact the manufacturer.

NOTE

Elements / Components sensitive to electrostatic discharges

- This device contains electronic components sensitive to electrostatic discharges. They may be damaged if they are touched by an electrostatically charged person or object. During electrostatic discharge, they will become defective immediately or will fail when energized.
- To minimize or even avoid all damage due to an electrostatic discharge, take all the precautions described in the standard EN 61340-5-1.
- Also ensure that you do not touch any of the live electrical components.

4. GENERAL INFORMATION

4.1. Manufacturer's address and international contacts

To contact the device manufacturer, use the following address:
Bürkert SAS
Rue du Giessen
F-67220 TRIEMBACH-AU VAL

The addresses of the international subsidiaries are available on the web page at: www.burkert.com

4.2. Warranty conditions

The condition governing the legal warranty is the conforming use of the MFM / MFC in observance of the operating conditions specified in this manual.

4.3. Information on the Internet

You can find the user manuals and technical data sheets regarding the MFM / MFC at: www.burkert.com

5. DESCRIPTION OF THE SYSTEM

5.1. General description

- Mass flow meter MFM types 8006, 8702 are devices designed for measuring the mass flow rate of clean, dry gases.
- Mass flow controller MFC types 8626, 8712 are devices designed for controlling the mass flow rate of clean, dry gases.

Type of device		Type of sensor
MFM	8006	Inline
	8702	MEMS
MFC	8626	Inline
	8712	MEMS

5.1.1. General operation of the Mass Flow Meter (MFM)

The MFM integrates a sensor for measuring the flow rate. The measured value for the mass flow rate is transmitted to a remote device via an analogue or a digital output (fieldbus).

5.1.2. General operation of the Mass Flow Controller (MFC)

The MFC comprises:

- a sensor for measuring the mass flow rate,
- a control electronics,
- a control valve with low-friction and high sensitivity.

5.2. Operation of an MFM or MFC sensor

- The integrated flow rate sensors use the thermal measurement principle (anemometric and calorimetric) to measure the mass flow rate. The main components are a heating resistor and a temperature probe. The gas which passes through the device modifies the temperature difference measured between both resistors.
- The thermal measurement principle allows the MFC to control the required mass flow rate completely independently of the pressure and temperature fluctuations in the application concerned.



To obtain an output signal for the effective, dynamic or uniform value, the damping of the output signal can be changed with the "Mass Flow Communicator" software (see section „10.1.4“).



On the MFMs and MFCs types 8712 and 8702, the integrated sensor technology requires filters to be fitted upstream of the product when highly soiled fluids are present.

5.3. Detailed operation of an MFC

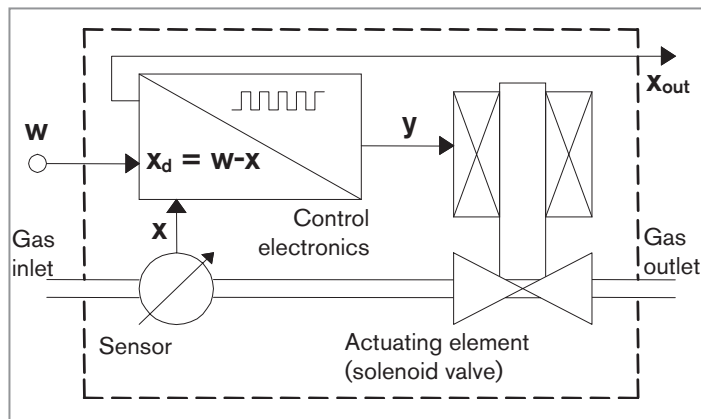

Fig. 1: Operating principle for the Mass Flow Controller

The control electronics compare the mass flow rate (x) measured by the integrated flow sensor with the mass flow rate setpoint value (w) supplied to the MFC. The control electronics then calculate the actuating variable (y) to be supplied to the solenoid valve to control its opening. The flow rate is either maintained at a constant value, or modified to a predefined profile.

The control operates independently of fluctuations in pressure or increases in the flow resistance which may be caused by soiling of the filter. The rapidly responding solenoid valve and the sensor dynamics define the overall response time.

The measured value for the mass flow rate is also transmitted (x_{out}) to a remote device via an analogue output or a digital output (fieldbus).

5.3.1. Control electronics

The control electronics:

- process the mass flow rate setpoint values and measured values,
- control the solenoid valve.

Setpoint value

The setpoint value (w) is transmitted either by an analogue input signal or digitally via the serial or the fieldbus interface. If the setpoint value is supplied by analogue transmission, the following assignments are applied:

Signal range	Setpoint associated with the range min.	Setpoint associated with the range max.
4...20 mA	4 mA, $w = 0\%$	20 mA, $w = 100\%$
0...20 mA	0 mA, $w = 0\%$	20 mA, $w = 100\%$
0...5 V	0 V, $w = 0\%$	5 V, $w = 100\%$
0...10 V	0 V, $w = 0\%$	10 V, $w = 100\%$

For the control of a system where quick flow rate changes are not permitted, a ramp function can be activated. The settings for a raising and a falling setpoint value can be set separately.



More detailed information on the ramp function and on all other functions can be found in the software documentation for the MFM / MFC.

Control settings

The initial control settings are set at the factory.

- Amplification factors:

After start-up, the controller operates with amplification factors dependent on the loop properties. When the autotune function runs, these are determined automatically. This function enables the control settings to be optimized for the system's actual conditions.

- Control dynamics setting:

The device has a setting which can change the control dynamics with the aid of the "Mass Flow Communicator" software (see section [„10.1.4“](#)). Its extreme effects are:

1. a very quick adjustment in which overshoots are possible.
This enables the controller to respond immediately to very low control deviations; which causes the control to be very turbulent,
2. a slower adjustment to the required flow rate. If the system is less dynamic, the behaviour of the controller may be damped so that minor fluctuations in the measured value or setpoint value are only adjusted slowly.

Zero point shut-off

A zero point shut-off is integrated to ensure the sealing function of the valve. This is activated if the following conditions occur at the same time:

Setpoint value $< 2\%$ of nominal flow rate Q_{nom} (with control range 1:50)	and	Measured value $< 2\%$ of nominal flow rate Q_{nom} (with control range 1:50)
---	-----	---



If the zero point shut-off is active, the PWM signal is set to 0 % so that the valve is completely closed.

5.3.2. MFC solenoid control valve

The solenoid valve used for an MFC is a direct-acting, normally closed solenoid control valve.

The orifice size of the solenoid valve is determined by the required nominal flow rate Q_{nom} , the pressure and temperature conditions in the process and the density of the operating fluid.



If the device is operated within the specified pressure range, the solenoid valve also takes over the sealing function together with the control function. Limitation: in the case of special hard seal materials, the sealing function cannot be ensured. In this case an additional shut-off valve may be required.

6. TECHNICAL DATA



ATTENTION

Risk of injury from pressure and outflow of fluid.

Important device-specific technical data is indicated on the name plate and the calibration plate (see section „6.1“).

- Observe the permitted fluid according to the name plate (depending on seal material).
- Observe the permitted pressure range on the calibration plate of the device.

6.1. Markings on the device

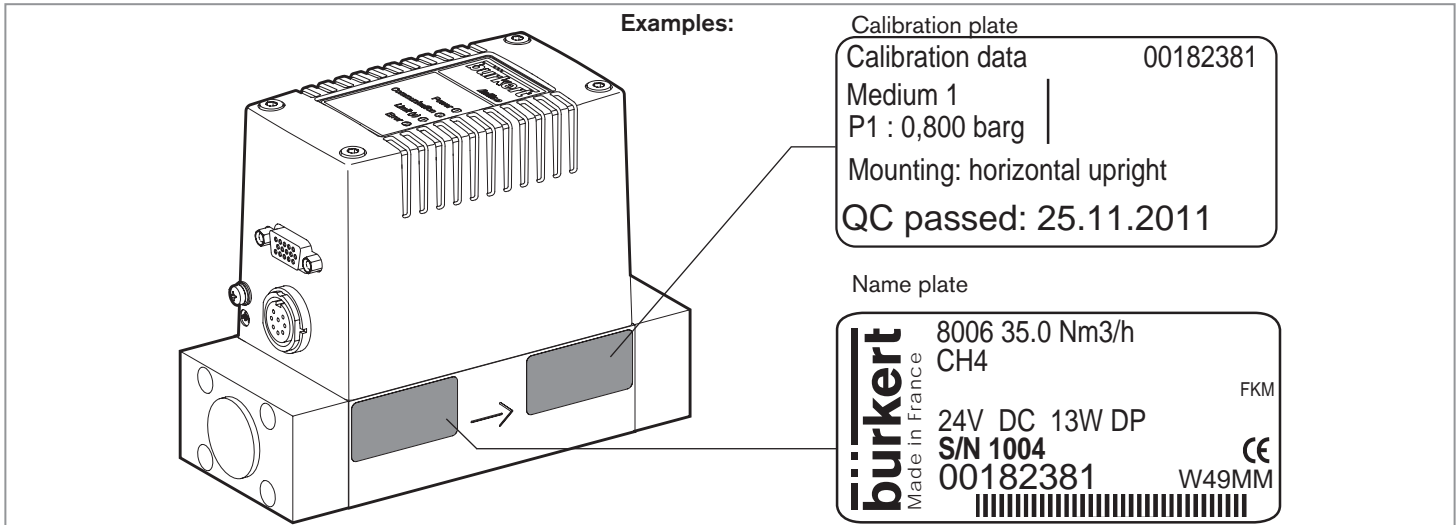

Fig. 2: Name plate, calibration plate

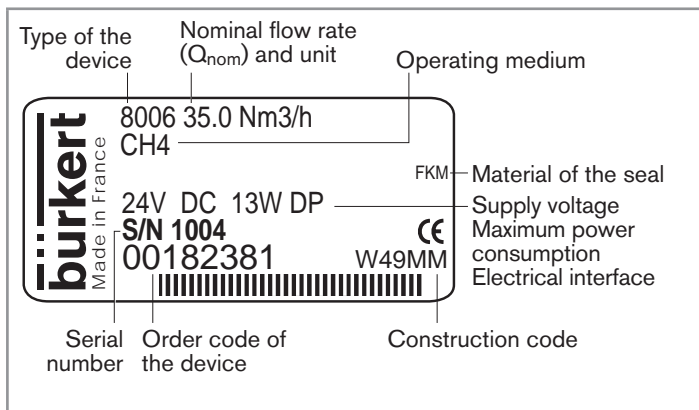

Fig. 3: Details of a name plate (example)

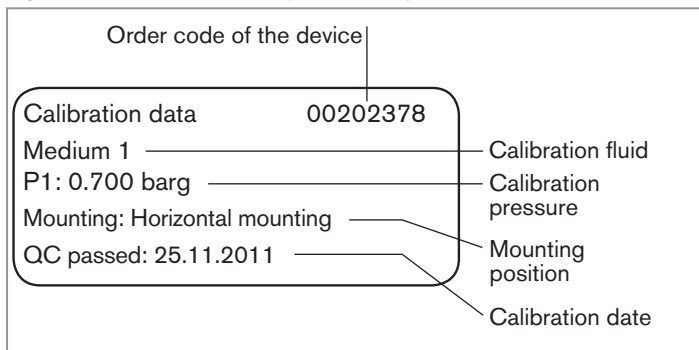

Fig. 4: Details of a calibration plate (example)

6.2. Conditions of use



WARNING

Risk of injury from malfunction due to effects of the weather!

The MFM / MFC is not designed for unrestricted use outdoors.

- Protect the device from direct sunlight.
- Observe the ambient temperature range of the device.
- Protect the device from humidity.

Setting	Value
Ambient temperature	Types 8702 / 8712: -10 °C to +50 °C Types 8006 / 8626: -10 °C to +45 °C For UL devices: 0 °C to 40 °C
Medium temperature	for oxygen: -10 °C to +60 °C for other fluids: -10 °C to +70 °C
Air humidity	< 95%, without condensation
Relative humidity for UL devices	80% up to a temperature of 31°C, with a linear decrease to a relative humidity of 50% at 40°C
Protection class according to EN 60529	Only if devices are cabled and the connectors are plugged in and tightened: IP65
Absolute height above sea level for UL devices	2000 m max.
Operating environment	Indoors, with pollution degree 2

6.3. Compliance to standards and directives

MFM/MFC conformity with the EC directives comes through the following standards:

- EMC: EN 61000-6-2, EN 61000-6-3.

The MFMs/MFCs compliant with ATEX Directive 94/9/EEC adhere to the standards below:

- EN 60079-15
- EN 61241-1.

The MFM / MFC UL devices conform to the following standards:

- UL 61010-1
- CAN/CSA-C22.2 no. 61010-1.

6.4. Mechanical data

The device may be mounted in a horizontal or vertical position: see the calibration plate and/or the calibration protocol.

Type	Base block material	Material of the housing
8006, 8626	1.4305 stainless steel, 1.4404 stainless steel or anodized aluminium	Painted pressure cast aluminium
8702, 8712	Stainless steel 1.4404	Polycarbonate (PC)

Sealing material: FKM or EPDM (see name plate)

Other parts of the solenoid control valve in contact with the medium: 1.4310, 1.4113 and 1.4305

6.5. Fluidic data

6.5.1. Overview of measurement specifications

Type	8006, 8626	8702, 8712
Full scale range ref. to N ₂ (lN/min)	16 ... 1500	0.01 ... 80
Measuring accuracy (after heating time)	± 1.5 % of the measured value ± 0.3 % of the full scale	± 0.8 % of the measured value ± 0.3 % of the full scale
Span/control range	1 : 50 *)	1 : 50 **)
Settling time (MFC) or response time (MFM) (ms)	< 500	< 150

*) 1:20 in case of vertical mounting, with downward flow.

***) Higher span (e.g. 1:100) possible on request.

Repeatability: ± 0.1% of the full scale.

6.5.2. Operating fluids

- Operating fluids: clean, dry gas.
- Operating fluid for UL devices: neutral, uncontaminated gas. Other hazardous gases are possible on request; the devices do not release any hazardous gases under normal operating conditions. However, to use an MFC with natural gas, only the solenoid valve Bürkert type 2875 can be used : in this case, the order key must include the letter "-D" (for example 8626-0100L-CH4-E-A-GM82-ALFF-D-08,0).
- Calibration fluid: operating fluid or air.
- Max. operating pressure: 10 bar (depending on valve nominal diameter).

To obtain the required measuring accuracy or control quality, but also to respect the safety requirements, the gas or gaseous mixture must conform to the following safety criteria, compliant with ISO standard 8573-1 (Compressed air - Part 1: Contaminants and purity classes):

- Maximum particle size and density: class 2:
Maximum particle size: 1 μm ¹⁾
Maximum particle density: 1 mg/m^3 ¹⁾
- Maximum dew point under pressure: class 4: 3 °C
- Maximum oil concentration: class 1: 0.01 mg/m^3 ¹⁾

¹⁾ For more information refer to ISO 8573-1

6.5.3. Pressure loss specifications

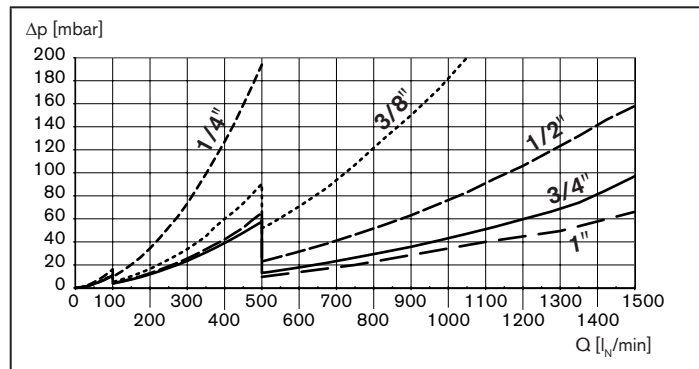

Fig. 5: Pressure loss diagram (ref. air, with 250 μm inlet filter), type 8006

The characteristic diagram shows the air pressure loss in the device for 3 different bases (up to 100 Nl/min, from 100 to 500 Nl/min, from 500 to 1500 Nl/min) and 4 different connections (1/4", 1/2", 3/4", 3/8" and 1").

For determining the pressure loss with another gas first calculate the equivalent air flow rate of the other gas.

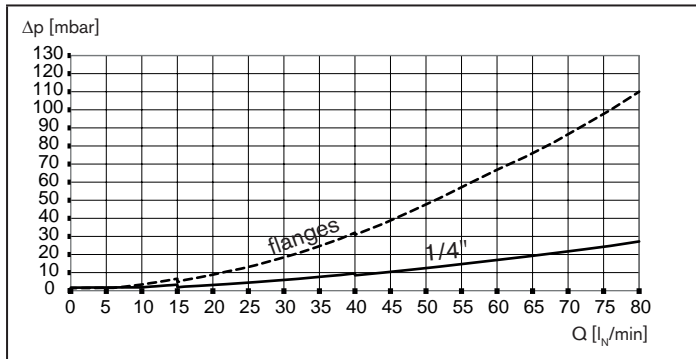

Fig. 6: Pressure loss diagram (ref. air, with 250 μm inlet filter), type 8702

The characteristic diagram shows the air pressure loss in the device for versions with flange connections and versions with 1/4" connections.

For determining the pressure loss with another gas first calculate the equivalent air flow rate of the other gas and respect the fluidics needed with the other gas.

6.6. Electrical data, devices with an 8 pin M16 female fixed connector

Operating voltage	24 V DC \pm 10%; residual ripple < 2% (5% for UL devices)			
Power supply (not provided) for UL devices	Power supply limited to class 2			
Power required (max. in Watt) depending on the type of the device	8006	8702	8626	8712
	12.5	5	36.5	14
MFC only: Analogue input (configurable)	<ul style="list-style-type: none"> ▪ 0/4 - 20 mA Max. input impedance: 300 Ω, resolution: 5 μA ▪ 0 - 5/10 V Min. input impedance: 20 kΩ, resolution: 2.5 mV 			
Binary inputs (configurable)	3 binary inputs Low active Connect to DGND for activation			
Analogue output (configurable)	<ul style="list-style-type: none"> ▪ 0/4 - 20 mA Max. load: 600 Ω, resolution: 20 μA ▪ 0 - 5/10 V Max. current: 10 mA, resolution: 10 mV 			
On certain versions: Fieldbus communication (alternative to "analogue input + outputs")	PROFIBUS DP V1, DeviceNet or CANopen			
Relay outputs (configurable)	2 relay outputs Potential-free changer 60 V, 1 A, 60 VA			
LEDs (configurable)	4 LEDs Status display for Power, Communication, Limit, Error			
Electrical connections	8 pin M16 female fixed connector, and 15-pin Sub-HD			
Additional connections for version with fieldbus	5 pin M12 male or female fixed connector, or 9 pin Sub-D female fixed connector			

6.7. Electrical data, devices with a 9 pin Sub-D male fixed connector, with RS485 interface

Operating voltage	24 V DC \pm 10%; residual ripple < 2% (5% for UL devices)	
Power supply (not provided) for UL devices	Power supply limited to class 2	
Power required (max. in Watt) depending on the type of the device	8006	8626
	12.5	36.5
Binary inputs (configurable)	1 binary input Low active Connect to DGND for activation	
Communication interface	RS485, full-duplex or half-duplex RS422, supports the MODBUS RTU protocole	
Relay outputs (configurable)	1 relay output Potential-free make contact 25 V, 1 A, 25 VA	
LEDs (configurable)	4 LEDs Status display for Power, Communication, Limit, Error	
Electrical connections	9 pin Sub-D male fixed connector	

7. INSTALLATION AND COMMISSIONING

7.1. Safety instructions



DANGER

Risk of injury due to high pressure in the installation.

- Shut off the gas flow, relief the pressure and drain the pipe before loosening the process connections.

Danger due to electrical voltage.

- Shut down and isolate the electrical power supply before carrying out work on the system.
- Observe all applicable accident protection and safety regulations for electrical equipment.

Risk of injury from the outflow of operating fluid

- Respect the prevailing regulations on accident prevention and safety relating to the operating fluids used.



WARNING

Danger due to nonconforming installation or commissioning

- Installation and commissioning can only be carried out by qualified and skilled staff with the appropriate tools.

Risk of injury due to the installation being accidentally energized or an uncontrolled restart.

- Take appropriate measures to avoid the installation being accidentally energized.
- Ensure the installation is subject to a controlled restart after any intervention on the device.

7.2. Prior to installation

→ Before installing the MFM / MFC, remove dirt from the pipes and fluid system components.

→ Connect a suitable filter ($\leq 25 \mu\text{m}$ mesh size) upstream to ensure that the operating fluid is kept clean.

NOTE

- Use a power supply unit with adequate power.
- Observe the maximum permitted residual ripple of the operating voltage.

7.3. Description of the MFM / MFC

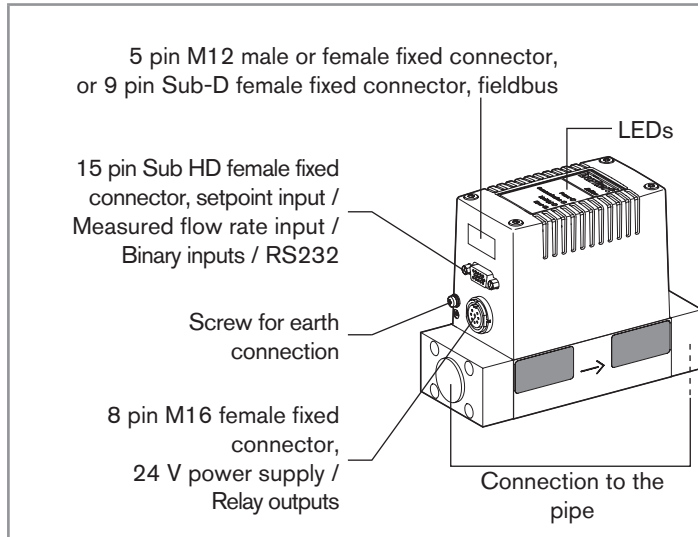

Fig. 7: Description of the devices with an 8 pin M16 female fixed connector

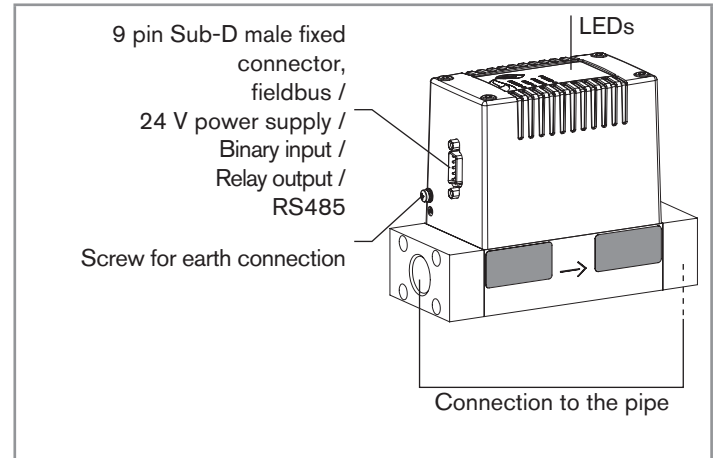

Fig. 8: Description of the devices with a 9 pin Sub-D male fixed connector, with RS485 interface

7.4. Sequence of the steps to be performed

1. Mechanical installation
2. Fluid installation
3. Electrical installation
4. Set the device parameters
5. Pressurize the lines with operating fluid
6. Flush the lines with operating fluid at the calibration pressure and deaerate completely

7.5. Setting the parameters

7.5.1. Setting the bus address



To ensure trouble-free adjustment, reset the device by switching off the power supply to the device.

The bus address of the device can be set either via the Bürkert "Mass Flow Communicator" software tool in the "Views" window → PROFIBUS / DeviceNet / CANopen or directly via the master bus.

The address must be reinitialized after a change on the slave and on the master. Depending on the bus, it may be necessary to send a corresponding telegram.

7.5.2. Pin assignment, devices with an 8 pin M16 female fixed connector

8 pin M16 female fixed connector		Pin	Assignment	
	1	24 V - Supply +		
	2	Relay 1 - centre contact		
	3	Relay 2 - centre contact		
	4	Relay 1 - break contact		
	5	Relay 1 - make contact		
	6	24 V - GND supply		
	7	Relay 2 - make contact		
	8	Relay 2 - break contact		
15 pin Sub-HD female fixed connector		Pin	Assignment of types 8626, 8712	Assignment of types 8006, 8002
	1 ¹⁾	Setpoint value input +	Not used	
	2 ¹⁾	Setpoint value input GND	Not used	
	3 ²⁾	Measured value output +		
	4	Binary input 2		
	5	12 V - output (for internal use only)		
	6	RS232 T x D (direct connection to PC)		
	7	Binary input 1		
	8	DGND (for binary inputs)		
	9	Internal use only (do not assign!)		
	10	12 V - output (for internal use only)		
	11	12 V - output (for internal use only)		
	12	Binary input 3		
	13 ²⁾	Measured value output GND		
	14	RS232 R x D (direct connection to PC)		
	15	DGND (for RS232 interface)		

¹⁾ On the fieldbus version of MFC types 8626 / 8712, these pins are not assigned.

²⁾ On the fieldbus version of MFC types 8626 / 8712 and MFM types 8702 / 8706, these pins are not assigned.

Pin assignment for fieldbus versions

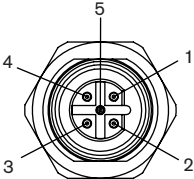
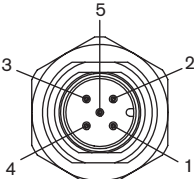
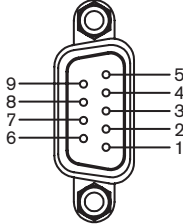
PROFIBUS DP M12 female fixed connector, B encoded (DP V1 max. 12 MBaud)	Pin	Assignment	
	1	VDD ¹⁾	
	2	R x D / T x D - N (line A)	
	3	DGND	
	4	R x D / T x D - N (line B)	
	5	Not used	
<p>¹⁾ Only use this voltage to energize the PROFIBUS termination resistor.</p>			
DeviceNet or CANopen M12 male fixed connector	Pin	Assignment	
	1	Shield	
	2	N. C. / 24V, depending on the version ²⁾	
	3	DGND	
	4	CAN_H	
	5	CAN_L	
<p>²⁾ If the power supply is connected to the DeviceNet or CANopen M12 male fixed connector, do not connect a power supply to the M16 female fixed connector.</p>			
9 pin Sub-D female fixed connector	Pin	Profibus assignment	DeviceNet assignment
	1	Shield (FE), functional earth	Shield (FE), functional earth
	2	N.C. (not connected)	CAN-L data line
	3	RxD/TxD-P line B	GND
	4	RTS control signal for repeater	N. C.
	5	GND data transmission potential	N. C.
	6	VDD supply voltage + (P5V)	N. C.
	7	N. C.	CAN-H data line
	8	RxD/TxD-N line A	N. C.
	9	N. C.	N. C.

7.5.3. Pin assignment, devices with a 9 pin Sub-D male fixed connector, with RS485 interface

9 pin Sub-D male fixed connector, with RS485		Pin	Assignment
	1	Binary input	
	2	GND	
	3	24 V - Supply voltage +	
	4	Relay - Make contact	
	5	Relay - Break contact	
	6 ¹⁾	TX+ (RS485 - Y)	
	7 ¹⁾	TX- (RS485 - Z)	
	8 ¹⁾	RX- (RS485 - B)	
	9 ¹⁾	RX+ (RS485 - A)	

¹⁾ For half-duplex operation, connect with jumpers, pin 6 to pin 9, and pin 7 to pin 8.

7.6. Mechanical installation

Observe the mounting position shown on the calibration plate or the calibration protocol.

7.7. Fluid installation



DANGER

Risk of injury due to high pressure in the installation.

- Shut off the gas flow, relief the pressure and drain the pipe before loosening the process connections.

Select the fluid connections suitable for the maximum flow rate and with the optimum pressure loss. There is no minimum upstream piping length to be observed.

On request, the device may be supplied with the fluid connections fitted.



WARNING

Danger from leaks

If flow rates are low and pressures high, ensure that the system is sealed to prevent incorrect metering or the operating fluid from leaking.

- To ensure that the seal is secure, observe the operations described below.

Install the fittings without subjecting them to any stresses. To seal the system properly, use fittings with olives.

Use a line with a suitable diameter and a smooth surface.

→ Cut the line squarely [1] and deburr [2].

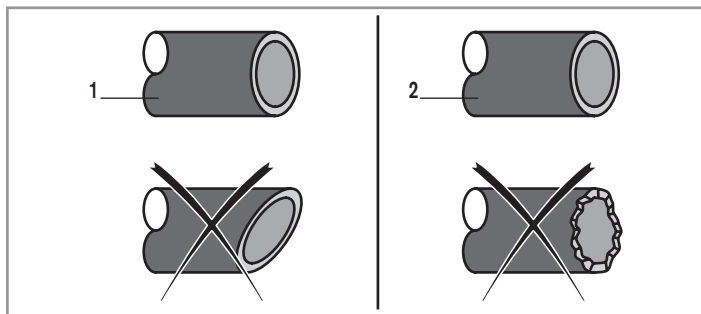

→ In order, fit the nut [A] and the olive onto the line.

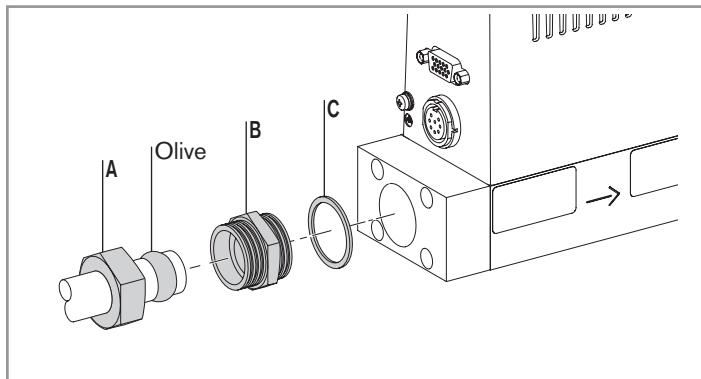

→ Fit the washer [C] and screw the fitting [B] to the device.

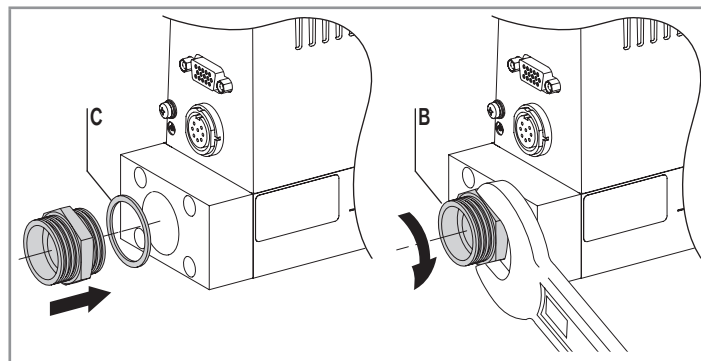

→ Insert the line and manually tighten the nut [A].

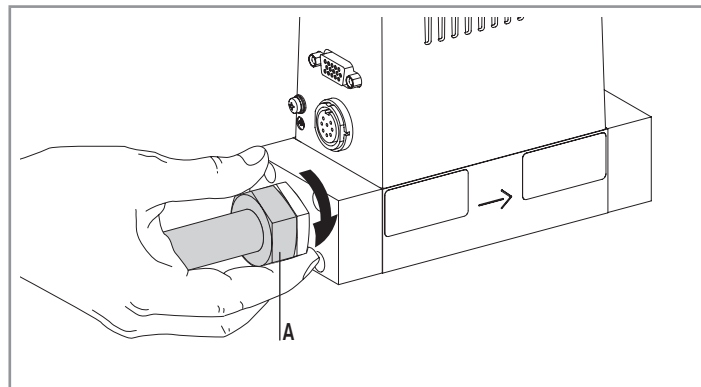

→ Finish tightening the nut with a suitable wrench to ensure the mounting is sealed.

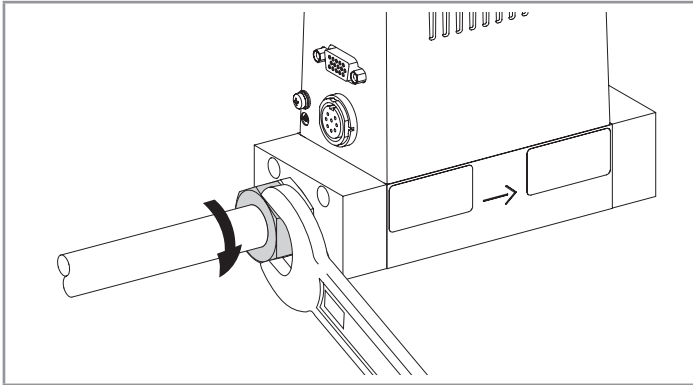

7.8. Electrical installation

DANGER

Risk of injury due to electrical shock

- Shut down and isolate the power supply before carrying out any work on the system.
- Observe all applicable accident protection and safety regulations for electrical equipment.

WARNING

Risk of fire and ignition due to electrostatic discharge

If the device is electrostatically charged, highly flammable fluid vapours may ignite if electrostatic discharge occurs.

- To avoid electrostatic charges, connect the device to the functional earth (FE) using the shortest possible cable with the largest possible cross section.

Danger from electromagnetic fields

If the FE connection is not connected, electromagnetic compatibility is not assured.

- Connect the device to the functional earth (FE) via the shortest possible cable (largest possible cross section).

NOTE

Important information to ensure trouble-free operation of the device

The GND or earth connections of the MFM / MFC must always be connected individually.

If all the GND connections are connected together and only a single common connection is set up with a view to activation, the analogue signals risk being subjected to fluctuations and interference.

→ Connect the functional earth (FE) to the screw indicated, for example using an earth terminal. The connection cable must

be as short as possible and its cross section must be as large as possible.

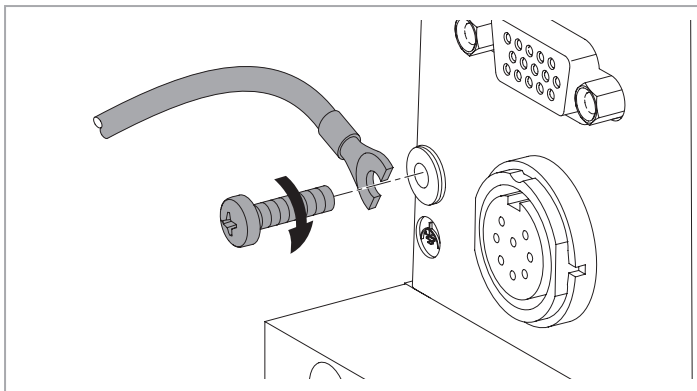

8. OPERATION AND FUNCTION

8.1. Safety instructions



WARNING

Risk of injury due to nonconforming operation.

Nonconforming operation could lead to injuries and damage the device and its surroundings.

- Operating personnel must familiarize themselves with the contents of the operating instructions.
- Observe the safety instructions and use the devices as indicated in this manual.
- Only adequately trained personnel may operate the device.

8.2. Operation

8.2.1. Operation, devices with an M16 female fixed connector

The devices with an M16 female fixed connector are operated by means of analogue standard signals and/or fieldbus communication as well as binary inputs. Four LEDs and two relay output signals indicate the operating state.

There is a serial interface (RS232) which can be used to connect to a computer, using the "Mass Flow Communicator" software.

Type 8626, 8712

Operation and function

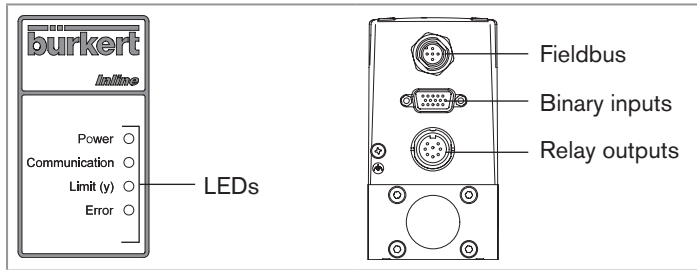

There is a serial interface (RS485) which can be used to connect to a computer, using the "Mass Flow Communicator" software.

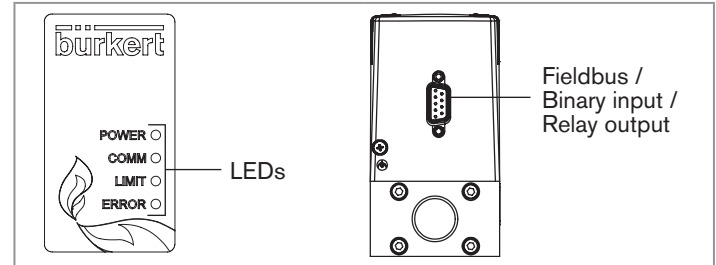

! Selecting the standard signals / Assigning the binary input ports

The standard signal type as well as the assignment of the binary input ports can be specified on order placement or configured via the "Mass Flow Communicator" PC software (see also section „10.1.4“).

▪ LED assignment / Binary output ports assignment

The "Communication" and "Limit(y)" LED assignment, and the binary output ports assignment can be configured via the software (see also section „10.1.4“).

! Assigning the binary input port

The assignment of the binary input port can be specified on order placement or configured via the "Mass Flow Communicator" PC software (see also section „10.1.4“).

▪ LED assignment / Binary output port assignment

The "Communication" and "Limit(y)" LED assignment, and the binary output port assignment can be configured via the software (see also section „10.1.4“).

8.2.2. Operation, devices with a Sub-D male fixed connector

The devices with a 9 pin Sub-D male fixed connector are operated by means of fieldbus communication as well as a binary input. 4 LEDs and 1 relay output signal indicate the operating state.

8.2.3. LED default assignment

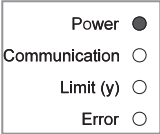
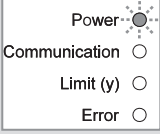
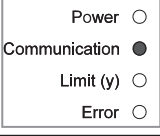
Indicator light status	Possible cause
Power LED (green) on 	The device is energized.
Power LED (green) flashes 	The <i>Autotune</i> function is in progress.
Communication LED (yellow) on 	The device is communicating via the fieldbus or the serial interface (RS232 / RS485 / USB).

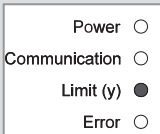
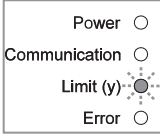
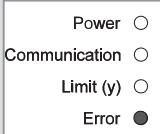
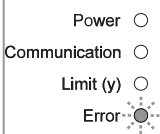
Indicator light status	Possible cause
Limit (y) LED (blue) on 	MFM: indicates that the measured value has almost reached the nominal flow rate. MFC: indicates that the actuating variable of the proportional valve has almost reached 100%. In practice this usually means that the pressure on the controller is not adequate to reach the required flow rate.
Limit (y) LED (blue) flashes 	The device is in an operating state other than the control mode or <i>Autotune</i> function.
Error LED (red) on 	Minor fault, for example the <i>Autotune</i> function has failed.
Error LED (red) flashes 	Major fault, sensor damaged, internal power supply voltage incorrect or operating pressure too high.

8.2.4. Inputs

Analogue input/output

The analogue input (MFC only) allows the setpoint value, i.e. the required flow rate value in the line, to be received.

The analogue output enables the measured flow rate value to be supplied to the device to which it is connected.

Bus connection (fieldbus version only)

The setpoint value received and the measured value are sent digitally via the fieldbus. It is possible to choose between PROFIBUS DP, DeviceNet and CANopen (see also the additional operating instructions for fieldbus devices).

Binary input ports

If the binary inputs are activated, different operations can be run on the MFC and the latter can be switched to a specific operating mode. This is achieved by connecting the binary input to DGND for at least 0.5 s.

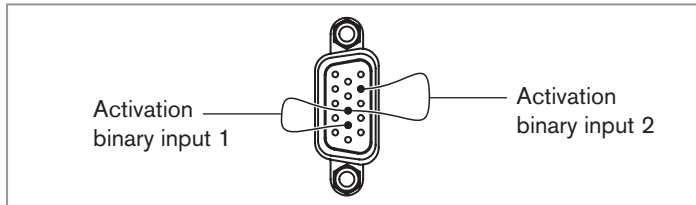

Fig. 9: Activation of the binary inputs, devices with an 8 pin M16 female fixed connector

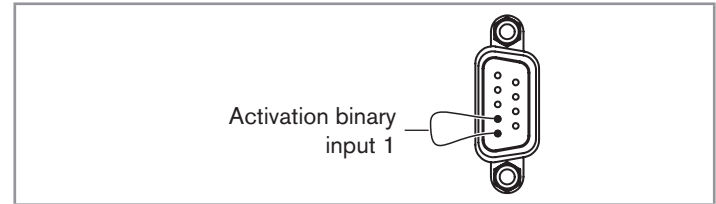

Fig. 10: Activation of the binary input, devices with a 9 pin Sub-D male fixed connector, with RS485

Input	Default assignment
Binary input 1	Autotune actuation
Binary input 2	<ul style="list-style-type: none"> Not used on devices with an 8 pin M16 female fixed connector.
Binary input 3	<ul style="list-style-type: none"> Not available on devices with a 9 pin Sub-D male fixed connector.

Table 11: Default assignment of binary input signals.

Function	Description
Actuate Autotune	Start of Autotune function for optimization of the control settings to the conditions available in the system (see section „8.3“).
Switch to specification 2	The calibration curve saved under Gas 2 as well as all settings entered there are used.
Totalizer Reset	The integrated totalizer (quantity integrator) is reset.
Start setpoint value profile	Start of the saved setpoint value profile (see section „8.3“).
Control mode	Enables the solenoid valve to be opened at a given value (see section „8.3“).
Correct safety value*	The safety value stored in the device is used as a flow rate setpoint value. In this case, the flow rate setpoint value received by the analogue input or fieldbus is ignored.
Close the valve completely*	Valve completely closed. In this case, the flow rate setpoint value is ignored.
Open the valve completely*	Valve completely opened. In this case, the flow rate setpoint value is ignored.

Table 12: Possible binary input functions.

* The operating principle of the binary input (active / inactive) can be selected for these functions

8.2.5. Relay output signals

Depending on the version, MFMs / MFCs are equipped with 1 or 2 relay outputs to indicate the operating state, limit values outside the maximum / minimum or a fault.

Output	Assignment
Relay output 1	y2 Limit
Relay output 2 ¹⁾	Fault (in case of a major fault, such as defective sensor or defective internal voltage)
¹⁾ Only available on a device with an 8 pin M16 female fixed connector	

Table 13: Relay output default assignment

Function	Description
Not used	No function is assigned to the relay output
Power ON	The device is energized.
Autotune activated	The <i>Autotune</i> function is in progress.
Gas 1 or 2 active	Calibration curve 1 or 2 is used.
User-defined calibration active	The device operates at the calibration adjusted by customer.
Binary input 1 or 2 active	Binary input 1 or 2 has been activated.
Activate relay output by fieldbus	The status of the relay outputs is specified via the fieldbus or the serial interface.
Correct safety value active	The safety value is used as the setpoint value.

Type 8626, 8712

Operation and function

Function	Description
Setpoint value profile active	The setpoint value profile stored in the device is used as the setpoint value.
Control mode active	The control mode is active, i.e. the solenoid valve is opened at a given value.
Close valve completely active	The close valve completely function is activated.
Open valve completely active	The open valve completely function is activated.
Defective power requirement	The power requirement of the device is monitored. If this value is outside defined limits, this function is actuated. An excessively high or low power requirement may indicate a defective device.
Defective internal power supply	The operating voltage of the device is monitored. If the defined limits exceed the maximum or drop below the minimum, this function is actuated.
Defective power supply to the sensor	The power supply voltage to the sensor is monitored. If the defined limits exceed the maximum or drop below the minimum, this function is actuated.
Defective data storage	If data storage is in the non-volatile memory of the device, a fault has occurred.
Sensor fault	The device is able to detect a defective sensor via a self-test. If this is the case, this function is activated.

Function	Description
MFI fault	The fieldbus module (MFI) is defective or incorrectly equipped. Fieldbus communication is not possible.
x Limit	The measured value has exceeded or dropped below a limit value which can be configured.
w Limit	The setpoint value has exceeded or dropped below a limit value which can be configured.
y2 Limit	The actuating variable has exceeded or dropped below a limit value which can be configured.
Totalizer Limit	The totalizer has exceeded or dropped below a limit value which can be configured.

Table 14: Relay output signals possible functions

8.3. MFC operating modes

The MFC can adopt different operating modes:

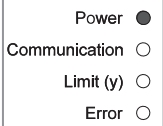
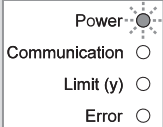
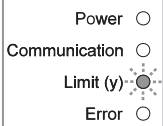
Operating mode	Status of the LEDs (default setting)	Binary input activation mode	This operating mode may be interrupted or ended by
Standard control mode (see section „8.3.1“)	Power LED (green) on 	-	<ul style="list-style-type: none"> ▪ <i>Autotune</i> function ▪ Safety function ▪ Setpoint value profile ▪ Control mode
<i>Autotune</i> function (see section „8.3.2“)	Power LED (green) flashes 	Input active for at least 0.5 s (permanent input activation leads to a function restart)	<ul style="list-style-type: none"> ▪ Safety function ▪ Device reset
Safety function (see section „8.3.3“)	Limit LED (blue) flashes 	As long as the input is active	-

Operating mode	Status of the LEDs (default setting)	Binary input activation mode	This operating mode may be interrupted or ended by
Setpoint value profile (see section „8.3.4“)	Limit LED (blue) flashes 	Input active for at least 0.5 s (permanent input activation leads to a function restart)	<ul style="list-style-type: none"> ▪ Autotune function ▪ Safety function ▪ Device reset
Control mode (see section „8.3.5“)	Limit LED (blue) flashes 	As long as the input is active	<ul style="list-style-type: none"> ▪ Autotune function ▪ Safety function ▪ Device reset

Table 15: Overview of the operating modes.

8.3.1. Standard control mode

In this operating mode, the flow rate is controlled to the specified setpoint value with a high dynamic.

The MFC is in this operating mode once energized, after a brief initialization phase. The green power indicator is on.

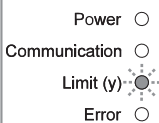
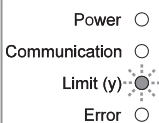
The setpoint value is specified via the analogue input or the fieldbus, depending on the device version.

The controller settings are set in such a way that setpoint value changes or actuating variables are corrected as quickly as possible without appreciable overshoot occurring.

The measured flow rate value is available on the analogue output or the fieldbus, depending on the device version.



For the MFC:

If the blue Limit (y) LED is on, this means that the control signal of the solenoid control valve is approaching the 100% limit (see section „9.3“).

The cause may be:

- either an insufficient pressure difference over the MFC, for example an insufficient inlet pressure,
- or a dirty inlet filter

This means that the set point cannot be achieved and a difference between the set point and the measured value (w-x) exists.



For the MFM:

If the blue Limit (y) LED is on, the measured mass flow is approaching the nominal flow rate or has even exceeded it (see section „9.3“).

If a high exceeding of the nominal flow rate occurs, a difference between the measured and the real flow rates may appear.

To permit an external reaction to this gap, a binary output is activated.

8.3.2. Autotune function



The *Autotune* function is run through during the final inspection in the factory, at the operating pressure and with the calibration fluid indicated in the calibration protocol.

Therefore, the re-actuation of this function is not essential.

However, the *Autotune* function should be activated if:

- the pressure conditions in the system have changed significantly,
- the calibration fluid does not correspond to the operating fluid.

In this operating mode, the device calculates and optimizes the control settings to the conditions present in the system.

The solenoid control valve is activated according to a predefined profile resulting in flow rate changes. Thereby several control settings are adjusted to the conditions on-site. These settings are stored in the non-volatile memory of the device at the end of a successful *Autotune*.

This function of the MFC is obtained by activating a binary input (configured on this function) for at least 0.5 s. The Power LED (green) flashes to signal that the function is in progress.



WARNING

Various flow rate changes occur when the *Autotune* is active.

- Do not switch off the power supply to the MFC.
- Keep the supply pressure constant.

→ Before activating the *Autotune* function, bring the medium pressure to a pressure close to the calibration pressure.

While the *Autotune* function is running, the MFC is not in control mode.

When the *Autotune* function ends, the MFC returns to the operating mode it was in prior to activation.

8.3.3. Safety function

In this operating mode, the device behaves as in control mode, except that the setpoint value is ignored and replaced by a predefined safety setpoint value. The default safety setpoint value is 0%. This can be modified with the "Mass Flow Communicator" software.

This function of the MFC is obtained by activating a binary input or via the fieldbus, depending on the configuration of the device. The Limit LED (blue) flashes to signal that the function is in progress.

8.3.4. Setpoint value profile

In this operating mode, the device behaves as in standard control mode, except that the external setpoint value is ignored and replaced by a predefined chronology of up to 30 flow rate values (configurable with the "Mass Flow Communicator" software).

This function of the MFC is obtained by activating a binary input (configured on this function) for at least 0.5 s. The Limit LED (blue) flashes to signal that the function is in progress.

If the setpoint value profile has been activated by binary input and the input has been reset, once the setpoint value profile has been executed, the device returns to the operating mode it was prior to activation.

8.3.5. Control mode

In this operating mode, the setpoint value enables a duty cycle to be directly supplied to the proportional valve, for example setpoint value 10% → duty cycle of the valve = 10%.

This function of the MFC is obtained by activating a binary input or via the fieldbus, depending on the configuration of the device (configurable with the "Mass Flow Communicator" software). The Limit LED (blue) flashes to signal that the function is in progress.

9. MAINTENANCE, TROUBLESHOOTING

9.1. Safety instructions



DANGER

Risk of injury due to high pressure in the installation.

- Shut off the gas flow, relief the pressure and drain the pipe before loosening the process connections.

Risk of injury due to electrical voltage.

- Shut down and isolate the electrical power supply before carrying out work on the system.
- Observe all applicable accident protection and safety regulations for electrical equipment.



WARNING

Risk of injury due to nonconforming maintenance.

- This work may only be carried out by qualified, authorized technicians trained for working in environments where there is a risk of explosion and using the appropriate tools.
- Ensure that the installation is subject to a controlled restart after the power supply is switched off.

9.2. Maintenance

The need to check and possibly to recalibrate the device depends on the application and no rule can be given.

We recommend to check the device every 2 years, with reference to an external standard.

Anyway it is common practice that a user checks their measurement equipment once a year and, if necessary, adjusts or recalibrates them.



ATTENTION

Risk of injury from operating faults and device failure if the device is opened.

Inside the device are elements to condition the flow and measure the flow rate. Work may only be carried out inside the device, for example for cleaning, as described in section „[9.2.1](#)“.

Any other work carried out inside the device causes a change to the sensor signal, requiring recalibration at the factory.

- Do not open the device.
- Cleaning other than that described in section „[9.2.1](#)“ and calibration may only be performed by the manufacturer.

9.2.1. Maintenance if used with highly soiled fluids

If highly soiled fluids are used:

- Regularly check that the stainless steel mesh filter disc [5] is not soiled.
- Clean or replace it if necessary.

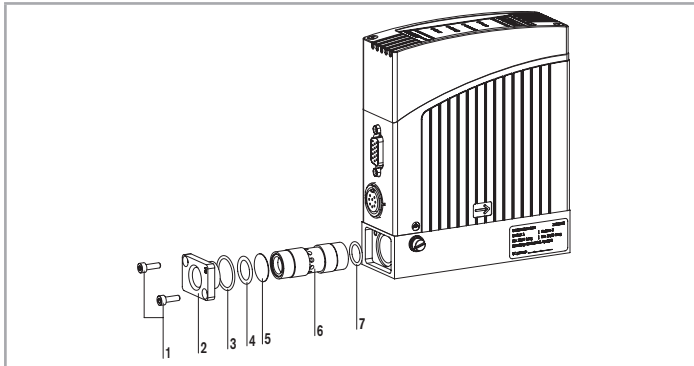

- 1 - Screws
- 2 - Inlet flange plate
- 3 - O-ring
- 4 - O-ring
- 5 - Stainless steel mesh filter
- 6 - Orifice tube
- 7 - O-ring

Fig. 16: Maintenance, Cleaning

Procedure:

- To gain access to the stainless steel mesh filter disc, detach the input flange plate [2] (see „Fig. 16“).
- Take out the stainless steel mesh filter disc.
- Clean the stainless steel mesh filter disc [5] using distilled water (not tap water), acetone, isopropanol or compressed air.
- Dry the parts after cleaning.
- Re-engage parts in the correct sequence and position (see „Fig. 16“). The fine mesh of the filter disc [5] must face the input flange plate [2].

9.2.2. Cleaning and recalibration at the factory

If the sensor is excessively soiled or damaged by the operating gas, the device may deviate significantly in terms of the mass flow rate measurement. Cleaning or replacement followed by recalibration at the factory will then be required.

NOTE

- Recalibration must be carried out at the factory as it requires the use of very precise references and a specific digital communication system.

9.3. Troubleshooting

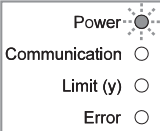
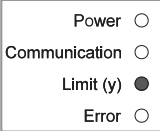
Problem	Possible cause	Recommended action
The Power LED is off	No power supply.	Check the electrical connections.
The Power LED flashes 	The <i>Autotune</i> function is in progress.	See section „8.3“.
The Power LED goes off periodically	The Power supply cuts out periodically; the device implements a reset.	Use a power supply with adequate power.
	The voltage drop in the connection cable is too high.	Increase the cable cross section. Reduce the cable length.
The Limit (y) LED comes on 	MFC: the solenoid valve adjustment has almost reached 100%. The setpoint value has not been obtained.	Increase the operating pressure (observe the maximum permitted supply pressure). Check the cable resistance and reduce if required. Check the system dimensions. Check the filters installed in the line and clean if required.
	MFM: the measured flow rate has almost reached or exceeded the nominal flow rate.	Reduce the flow rate.

Problem	Possible cause	Recommended action
The limit (y) LED is flashing 	The device is in an operating state other than standard control mode or the <i>Autotune</i> function.	See section „8.3“.
The Error LED is on 	Minor fault; for example the <i>Autotune</i> function has failed.	Repeat the <i>Autotune</i> function or reset the device to acknowledge the fault.
The Error LED flashes 	The residual ripple of the supply voltage is too high.	Use a power supply with a smooth output voltage at the required power.
	A major fault has occurred, for example: defective sensor or internal voltage fault.	Return the device to the manufacturer to have the fault repaired.
	The sensor was operated above the permitted maximum operating pressure.	Reduce the operating pressure. Return the device to the manufacturer to have the fault repaired.
No flow rate available	The setpoint value is below the limit for the zero point shut-off.	Increase the setpoint value to > 2% of the nominal flow rate.
	The device is in an operating state other than standard control mode.	Check the operating state; see also section „8.3“.
	The lines have been sized too large or may not yet have been completely deaerated.	Deaerate the lines. Change the line diameter.

Problem	Possible cause	Recommended action
The measured value fluctuates	The earth connection (FE) is not correct.	Connect the FE to the earthing point (cable as short as possible, wire at least 2.5 mm ²).
	The controller must continuously correct fluctuations in an unstable pressure supply, e.g. by pumping.	Connect a suitable pressure controller upstream. Install a buffer tank to absorb pressure fluctuations.
	The residual ripple of the supply voltage is too high.	Use a power supply with a smooth output voltage at the required power.
Setpoint value at 0%, but the fluid is circulating	The operating pressure is above the operating pressure maintained by the proportional valve.	Reduce the operating pressure. Return the device to the manufacturer to have the fault repaired.
Setpoint value = 0%, valve is closed, no flow rate in the line; but the measured flow rate is not zero	The mounting position of the device is incorrect.	Install the MFC in the mounting position shown in the calibration protocol or the calibration plate and run an <i>Autotune</i> function to adjust to the operating conditions.
	A fluid other than that designated by the calibration is used.	→ Use the designated calibration fluid. → or send the device back to the manufacturer to have it calibrated with the new fluid.
Setpoint value is not reached	The filter is blocked.	Clean or replace the filter.
	The primary pressure is too low.	Increase primary pressure to calibration pressure.
	The back pressure is too high.	Check components for soiling downstream of the device and if required clean.

10. ACCESSORIES / SPARE PARTS



ATTENTION

Risk of injury and/or damage caused by the use of unsuitable parts.

Incorrect accessories and unsuitable replacement parts may cause injuries and damage the device and the surrounding area.

- Use only original accessories from Bürkert.

10.1. Accessories

The Bürkert accessories indicated below are recommended to ensure problem-free operation, maintenance and repair of the device.

10.1.1. Electrical accessories, devices with an 8 pin M16 female fixed connector

Types	Item	Order code
8006, 8702, 8626, 8712	8 pin M16 male connector (to be soldered)	918 299
	8 pin M16 male connector, with 5 m cable, with stripped end	787 733
	8 pin M16 male connector, with 10 m cable, with stripped end	787 734
	15 pin Sub-HD male connector with 5 m cable, with stripped end	787 735
	15 pin Sub-HD male connector with 10 m cable, with stripped end	787 736
	RS232 adapter for PC connection with an extension cable (order code 917039)	654 757
	9 pin Sub-D extension cable, RS232, 2 m	917 039
	RS422 adapter	666 370
	USB adapter	670 696
	USB cable, 2 m	772 299
	Software "Mass Flow Communicator"	Can be downloaded at www.burkert.com

Types	Item	Order code
Profibus version	Straight M12 male connector (code B)	918 198
	Straight M12 female connector (code B)	918 447
	PROFIBUS* Y-piece	902 098
	PROFIBUS T-piece	918 531
	PROFIBUS termination resistor, male connector, code B	902 553
	GSD file	Can be downloaded at www.burkert.com
DeviceNet / CANopen version	Straight M12 male connector (code A)	917 115
	Straight M12 female connector (code A)	917 116
	DVN/CAN* Y-piece	772 420
	DVN/CAN terminal resistor Male connector (code A)	772 424
	Female connector (code A)	772 425
	EDS file for DeviceNet	Can be downloaded at www.burkert.com

* The two previous M12 connectors cannot be used side by side on the Y-junction. At least one of the two M12 connectors must be a commercial connector with a smaller diameter.

10.1.2. Electrical accessories, devices with a 9 pin Sub-D male fixed connector with RS485

Accessory	Order code
9 pin Sub-D female connector (to be soldered)	917 623
USB adapter	670 693
USB cable, 2 m	772 299

10.1.3. Fluid accessories

The MFM / MFC are equipped with a connection plate which uses a DIN ISO 228/1 thread process connection.

A threaded fitting available as an accessory is used to connect the device to a line:

- the connection to the device side has a DIN ISO 228/1 thread,
- the connection to the line side is available in a range of dimensions.



A sealing ring must be ordered for each screw fitting!

Type 8626, 8712

Accessories / Spare parts

Connection to the device, with DIN ISO 228/1 thread	Diameter of the line	Order code of the olive connection	Order code of the seal
G 1/4	6 mm	901 538	901 575
G 1/4	8 mm	901 540	901 575
G 1/4	1/4 "	901 551	901 579
G 1/4	3/8 "	901 553	901 579
G 3/8	8 mm	901 542	901 576
G 3/8	10 mm	901 544	901 576
G 3/8	1/4"	901 555	901 580
G 3/8	3/8"	901 556	901 580
G 1/2	10 mm	901 546	901 577
G 1/2	12 mm	901 548	901 577
G 1/2	1/2"	901 557	901 581
G 1/2	3/4"	901 558	901 581
G 3/4	12 mm	901 549	901 578
G 3/4	3/4"	901 559	901 582



Other accessories for the fluid connection of an MFM / MFC can be found under Type 1013 in the Bürkert accessories catalogue.

10.1.4. Mass Flow Communicator (Software)

The "Mass Flow Communicator" software is made for the communication with the Mass Flow Controllers and Liquid Flow Controllers supplied by Bürkert.



The software runs on the Windows platform and communicates with the MFM / MFC via a serial interface (RS232 / RS485 / USB).

This software enables:

- information specific to the device to be read,
- the assignment of binary inputs and outputs to be changed,
- the assignment of LEDs to be changed,
- various functions to be activated,
- certain dynamic properties to be modified,
- a user specific calibration to be performed,
- the firmware to be updated,
- the bus address to be set,
- ...

10.1.5. Additional documentation

Designation	Order code
Supplement to the operating instructions for fieldbus devices	804 553
Contamination Declaration	806 075
"Configuration via PROFIBUS with GDS file" addendum	805 923

10.2. Spare part

Designation	Order code
Stainless steel mesh filter, mesh size 250 µm, for 8626 / 8006 (standard fluid base)	646 808
Stainless steel mesh filter, mesh size 250 µm, for 8626 / 8006 (high fluid flow rate base)	651 694
Stainless steel mesh filter, mesh size 250 µm, for 8702	654 733
Stainless steel mesh filter, mesh size 25 µm, for 8712	676 329

11. SHUTDOWN

11.1. Safety instructions



DANGER

Danger due to high pressure in the installation.

- Shut off the gas flow, relieve the pressure and drain the pipe before loosening the process connections.

Danger from the outflow of operating fluid.

- Respect the prevailing regulations on accident prevention and safety relating to the operating fluids used.

Danger due to electrical voltage.

- Shut down and isolate the electrical power supply before carrying out work on the system.
- Observe all applicable accident protection and safety regulations for electrical equipment.



WARNING

Risk of injury from nonconforming dismantling.

- Maintenance must only be carried out by qualified and skilled staff with the appropriate tools.

11.2. Dismounting of the MFM / MFC

Procedure:

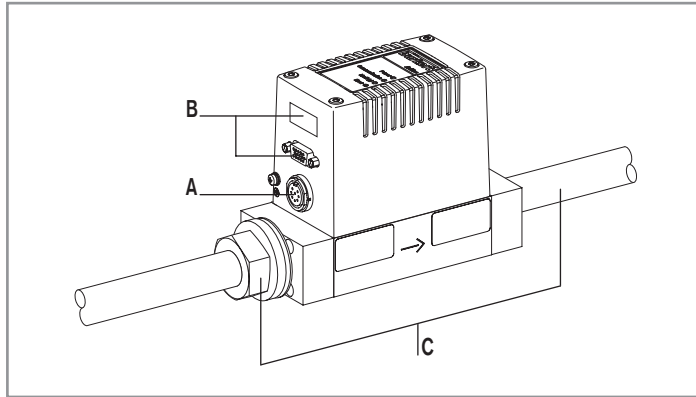

- Relieve the operating medium pressure in the system.
- Control the solenoid valve to open.
- Clean the device using a neutral fluid (nitrogen, for example).
- Relieve the rinsing medium pressure in the system.
- Switch off the power supply [A].
- Disconnect the electrical connections [B].
- Disconnect the fluid connections [C].
- Remove the MFM / MFC.

12. PACKAGING, STORAGE, TRANSPORT

12.1. Packaging, Transport

NOTE

Damage due to transport

Inadequately protected equipment may be damaged during transport.

- Remove all cables, connections, separate filters and installation material.
- Clean and air contaminated devices.
- Protect fluid connections from damage and leaks by fitting protective caps and seal.
- Pack the device in two suitable bags, sealed with protective film.
- During transportation protect the device against humidity and dirt in shock-resistant packaging.
- Do not expose the device to temperatures outside the storage temperature range.

12.2. Storage

NOTE

Poor storage can damage the device.

- Store the device in a dry place away from dust.
- Storage temperature: -10 °C to +70 °C.

13. RETURNING THE DEVICE



No work or tests will be carried out on the device until there is a valid contamination declaration.

The Contamination Declaration can be downloaded from our homepage or requested from your local after-sales service.

www.buerkert.fr → [Service](#) → [Servicing/Maintenance/Commissioning](#) → [Contamination Declaration](#)

To return a device already in use, a returns number is required.

If you would like to return a device already in use to Bürkert, proceed as follows:

- Complete the Contamination Declaration.
- Send the declaration to the address indicated on the form:
Bürkert will fax or e-mail you a service number for confirmation.
- Pack the device in consideration of the information in section [„12.1“](#).
- Return the device to Bürkert with the contamination declaration, and mention the service number given before.

Address:

Bürkert Fluid Control Systems
Corporate Quality / Complaint Management
Chr.-Bürkert-Str. 13-17
D-74653 Ingelfingen
Tel. + 49 (0) 7940 - 10 91 599
Fax + 49 (0) 7940 - 10 91 490
E-mail: service.international@burkert.com

14. DISPOSAL OF THE PRODUCT

- Sort out used products according to their type.
- Dispose of the device and its packaging in an environmentally-friendly way.

NOTE

Damage to the environment caused by products contaminated by fluids.

- Keep to the existing provisions on the subject of waste disposal and environmental protection.



Comply with the national and/or local regulations which concern the area of waste disposal.

www.burkert.com