

## Type 8022

Flow Transmitter / Pulse divider  
Durchflusstransmitter / Impulsteiler  
Transmetteur de débit / Diviseur d'impulsions



Operating Instructions  
(device version 2 and higher)  
Bedienungsanleitung (ab Geräte-Version 2)  
Manuel d'utilisation (à partir de la version 2 de l'appareil)

We reserve the right to make technical changes without notice.  
Technische Änderungen vorbehalten.  
Sous réserve de modifications techniques.

© Bürkert SAS, 2011-2019

Operating Instructions 1901/05\_EU-ML 00809506 Original FR

<b>1</b>	<b>OPERATING INSTRUCTIONS.....</b>	<b>3</b>
1.1	Symbols used .....	3
1.2	Definition of the term "device" .....	3
<b>2</b>	<b>INTENDED USE.....</b>	<b>4</b>
<b>3</b>	<b>BASIC SAFETY INSTRUCTIONS.....</b>	<b>5</b>
<b>4</b>	<b>GENERAL INFORMATION.....</b>	<b>6</b>
4.1	Contact .....	6
4.2	Warranty conditions .....	6
4.3	Information on the Internet.....	6
<b>5</b>	<b>DESCRIPTION .....</b>	<b>7</b>
5.1	General description .....	7
5.2	Combined sensor .....	7
5.3	Description of the rating plate .....	8
<b>6</b>	<b>TECHNICAL DATA.....</b>	<b>9</b>
6.1	Conformity to standards and directives .....	9
6.1.1	UL certification .....	9
6.2	Operating conditions .....	9
6.3	Mechanical data.....	10
6.4	Electrical data .....	10
<b>7</b>	<b>INSTALLATION AND COMMISSIONING .....</b>	<b>11</b>
7.1	Wiring a version with cable gland .....	11
7.1.1	Using the device as a flow transmitter .....	11
7.1.2	Using the device as a pulse divider .....	12
7.2	Wiring a version with a 4-pin M12 male connector .....	13
7.2.1	Using the device as a flow transmitter .....	14
7.2.2	Using the device as a pulse divider .....	14
7.3	Mounting the device on a flow sensor .....	16
<b>8</b>	<b>ADJUSTMENT .....</b>	<b>17</b>
8.1	Display unit.....	17

8.2	Operation as a flow transmitter .....	18
8.3	Operation as a pulse divider.....	18
8.4	Operating levels.....	18
8.4.1	Switching between the operating levels .....	19
8.5	Main menu of the configuration level .....	20
8.5.1	<b>Unit</b> – Setting the unit for the flow rate .....	20
8.5.2	<b>InP (Input)</b> – Entering the K factor of the fitting or selecting a preset K factor.....	21
8.5.3	<b>Out (Output)</b> – Setting the output signal .....	23
8.5.4	<b>dAtA (Data)</b> – Uploading and downloading the device settings.....	24
9	MAINTENANCE, TROUBLESHOOTING.....	26
9.1	Maintenance work .....	26
9.2	Error messages .....	26
9.3	Default values.....	26
10	ACCESSORIES .....	27
11	PACKAGING AND TRANSPORT .....	27
12	STORAGE.....	27
13	DISPOSAL .....	27

# 1 OPERATING INSTRUCTIONS

The Operating Instructions describe the entire life cycle of the device. Keep these instructions in a location which is easily accessible to every user, and make these instructions available to every new owner of the device.

**The Operating Instructions manual contains important safety information.**

Read the complete Operating Instructions. Pay special attention to the chapters [Basic Safety Instructions](#) and [Intended Use](#).

- ▶ Read the complete Operating Instructions.

## 1.1 Symbols used



### CAUTION

**Warns of a possible danger!**

- ▶ Failure to observe this warning may result in a moderate or minor injury.

### NOTICE

**Warns of damage to property!**

- ▶ Failure to observe the warning may result in damage to the device or the equipment.



Indicates important additional information, tips and recommendations.



refers to information in these Operating Instructions or in other documentation.

- ▶ Indicates an instruction to be carried out to avoid a danger, a warning or a possible risk.

→ Indicates a procedure to be carried out.

- ✔ Indicates the result of a specific instruction.

## 1.2 Definition of the term "device"

In these Operating Instructions, the term "device" always refers to the flow transmitter type 8022 or the pulse divider type 8022.

## 2 INTENDED USE

Use of the device that does not comply with the Operating Instructions could present risks to people, nearby installations and the environment.

The flow transmitter type 8022, associated to a Bürkert flow sensor, converts the frequency signal generated by the flow sensor into an analogue 4...20 mA current signal.

The pulse divider type 8022, associated to a Bürkert flow sensor, converts the frequency signal generated by the flow sensor into an adjustable frequency signal.

- ▶ The device is designed for use in industrial environments.
- ▶ Use the device in compliance with the characteristics and commissioning and use conditions specified in the contractual documents and in the Operating Instructions.
- ▶ Do not use the device for security applications.
- ▶ Do not use the device outdoors.
- ▶ Protect the device against electromagnetic interference and ultraviolet rays.
- ▶ Use the device only if in perfect working order.
- ▶ Requirements for the safe and proper operation of the device are proper transport, storage and installation, as well as careful operation and maintenance.
- ▶ Only use the device as intended.

### 3 BASIC SAFETY INSTRUCTIONS

This safety information does not take into account any contingencies or occurrences that may arise during installation, use and maintenance of the product.

The operating company is responsible for the respect of the local safety regulations including for the staff safety.



#### Various dangerous situations

To avoid injury:

- ▶ Do not use the device in explosive atmospheres.
- ▶ Do not use the device in an environment incompatible with the materials it is made of.
- ▶ Do not subject the device to mechanical stress.
- ▶ Do not make any modifications to the device.
- ▶ Prevent any unintentional power supply switch-on.
- ▶ Only qualified and skilled staff can carry out the installation and maintenance work.
- ▶ Guarantee a defined or controlled restarting of the process, after a power supply interruption.
- ▶ Observe the general technical rules.

#### NOTICE

##### Electrostatic sensitive components/modules.

The device contains electronic components, which react sensitively to electrostatic discharge (ESD). Contact with electrostatically charged persons or objects is hazardous to these components. In the worst case scenario, they will be destroyed immediately or will fail after start-up.

- ▶ Observe the requirements in accordance with EN 61340-5-1 to minimize and even avoid the possibility of damage caused by a sudden electrostatic discharge.
- ▶ Also, ensure that you do not touch electronic components when the power supply voltage is present.

## **4 GENERAL INFORMATION**

### **4.1 Contact**

To contact the manufacturer of the device, use following address:

Bürkert SAS

Rue du Giessen

BP 21

F-67220 TRIEMBACH-AU-VAL

You may also contact your local Bürkert sales office.

The addresses of our international sales offices are available on the internet at: [www.burkert.com](http://www.burkert.com)

### **4.2 Warranty conditions**

The condition governing the legal warranty is the conforming use of the device in observance of the operating conditions specified in these Operating Instructions.

### **4.3 Information on the Internet**

The Operating Instructions and data sheets for type 8022 can be found on the Internet at: [www.burkert.com](http://www.burkert.com)



## 5 DESCRIPTION

### 5.1 General description

The device must be combined with a Bürkert flow sensor. To be combined to the flow sensor, the device has a 4-pin female connector. Refer to chap. [5.2](#) to know which sensor you can combine with the device.

Upon delivery, the device can be fitted or not with a display unit. You need a display unit to do the settings for a correct operation of the device. For example, to enter the K factor of the fitting in which the combined flow sensor is inserted in or mounted on. The display unit is available as an accessory: refer to chap. [10 Accessories](#).

The device is available either with a cable gland or a 4-pin M12 male connector.

The device has both a 4...20 mA current output and a transistor output. Thus it can operate either as a flow transmitter or as a pulse divider.

- If the device operates as a flow transmitter, it converts the frequency signal generated by the combined flow sensor into an analogue 4...20 mA current signal.
- If the device operates as a pulse divider, it converts the frequency signal generated by the combined flow sensor into an adjustable frequency signal.

To operate the device as a flow transmitter, do the following:

- Wire the 4...20 mA current output (2-wire connection).
- By default, the device output is configured to operate as a 4...20 mA current output. Use a display unit to set the flow rate range associated to the 4...20 mA current output. Refer to chap. [8.5.3 Out \(Output\) – Setting the output signal](#).
- Do the other necessary settings. Refer to chap. [8 Adjustment](#).

To operate the device as a pulse divider, do the following:

- Wire the transistor output (3-wire connection).
- Use a display unit to change the operating mode. To change the operating mode, change the settings of the device output. Refer to chap. [8.5.3 Out \(Output\) – Setting the output signal](#).
- Do the other necessary settings. Refer to chap. [8 Adjustment](#).

### 5.2 Combined sensor

- The flow transmitter type 8022 must be combined with a Bürkert flow sensor with a transistor output, in the Low Power version of the following types: 8020, 8030, 8070, SE30.
- The pulse divider type 8022 must be combined with a Bürkert flow sensor with a transistor output of the types 8020, 8030, 8070, SE30.

### 5.3 Description of the rating plate

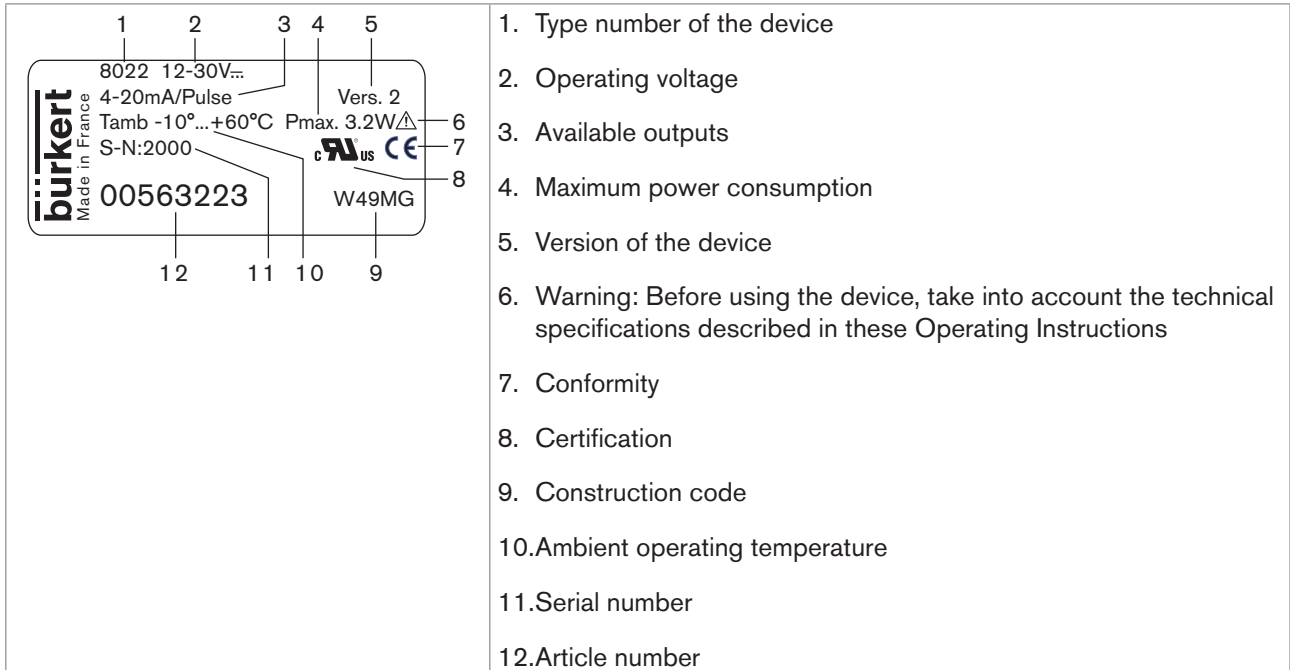

Fig. 1: Rating plate (example)

## 6 TECHNICAL DATA



### 6.1 Conformity to standards and directives

The applied standards, which verify conformity with the EU directives, can be found on the EU-type examination certificate and/or the EU declaration of conformity (if applicable).

#### 6.1.1 UL certification

Devices with variable key PU01 or PU02 are UL-certified devices and comply also with the following standards:

- UL 61010-1
- CAN/CSA-C22.2 n°61010-1

Identification on the device	Certification	Variable key
	UL recognized	PU01
	UL listed	PU02

### 6.2 Operating conditions

Ambient temperature (operating)	-10...+60 °C
Protection class	IP65 according to EN 60529, if the following conditions are respected: <ul style="list-style-type: none"> <li>▪ Cable gland wired or blanked-off, or female connector plugged-in and tightened</li> <li>▪ Nut of the cable gland tightened with a torque of 1 N·m ± 20 % (0,74 lbf·ft ± 20 %).</li> <li>▪ Housing closed and screw tightened with a torque of 0,3 N·m ± 20 % (0,22 lbf·ft ± 20 %), or display unit plugged on the device and screw tightened with a torque of 0,3 N·m ± 20 % (0,22 lbf·ft ± 20 %) at the factory.</li> </ul>
Combined flow sensor <ul style="list-style-type: none"> <li>▪ Flow transmitter</li> <li>▪ Pulse divider</li> </ul>	<ul style="list-style-type: none"> <li>▪ Bürkert flow sensor with a transistor output, in the Low Power version of the types 8020, 8030, 8070, SE30.</li> <li>▪ Bürkert flow sensor with a transistor output, of the types 8020, 8030, 8070, SE30.</li> </ul>

### 6.3 Mechanical data

Fastening	<ul style="list-style-type: none"> <li>▪ device without display unit</li> <li>▪ device with display unit</li> </ul>	<ul style="list-style-type: none"> <li>▪ 1 M3 x 35 screw</li> <li>▪ 1 M3 x 45 screw</li> </ul>
Housing material	polyamide/polycarbonate	
Material of the seals	<ul style="list-style-type: none"> <li>▪ seal between the device and the sensor</li> <li>▪ seal for the cover</li> </ul>	<ul style="list-style-type: none"> <li>▪ NBR</li> <li>▪ EPDM</li> </ul>

→ Refer to the datasheet of the device for the complete mechanical data. The datasheet is available at [www.burkert.com](http://www.burkert.com)

### 6.4 Electrical data

Electrical connection	<ul style="list-style-type: none"> <li>▪ Version with cable gland: 4-pin terminal strip, 1.5 mm<sup>2</sup> max. wire section, 6...7 mm cable diameter</li> <li>▪ 4-pin M12 male connector</li> </ul>	
Voltage supply, 12...30 V DC	<ul style="list-style-type: none"> <li>▪ filtered and regulated</li> <li>▪ SELV circuit at a non dangerous energy level</li> <li>▪ tolerance : <math>\pm 10\%</math></li> <li>▪ residual ripple : <math>&lt; 5\%</math></li> </ul>	
Frequency input	1...600 Hz, sensor supply voltage approximately V+ minus 1 V	
Current output	4...20 mA	
<ul style="list-style-type: none"> <li>▪ Uncertainty of the output value</li> <li>▪ Min. voltage drop at the device terminals</li> <li>▪ Loop impedance</li> </ul>	<ul style="list-style-type: none"> <li>▪ <math>\pm 1,5\%</math> of the full scale</li> <li>▪ <math>&lt; 10</math> V at 20 mA</li> <li>▪ max. 100 <math>\Omega</math> at 12 VDC, max. 700 <math>\Omega</math> at 24 VDC, max. 1000 <math>\Omega</math> at 30 VDC</li> </ul>	
Transistor output	NPN or PNP, 50 mA max. current, frequency up to 600 Hz	
<ul style="list-style-type: none"> <li>▪ Uncertainty of the output value</li> </ul>	<ul style="list-style-type: none"> <li>▪ <math>\pm 1\%</math> of the measured value</li> </ul>	
Maximum power consumption	<ul style="list-style-type: none"> <li>▪ Operating as a flow transmitter (4...20 mA output in a 2-wire system)</li> <li>▪ Operating as a pulse divider (NPN/PNP output in a 3-wire system)</li> </ul>	<ul style="list-style-type: none"> <li>▪ 0,6 W</li> <li>▪ 3,2 W, from which               <ul style="list-style-type: none"> <li>- 0,2 W for the device,</li> <li>- max. 1,5 W for the flow sensor,</li> <li>- max. 1,5 W for the NPN/PNP output</li> </ul> </li> </ul>

MAN 1000217540 EN Version: D Status: RL (released | freigegeben) printed: 11.01.2019

## 7 INSTALLATION AND COMMISSIONING

### 7.1 Wiring a version with cable gland

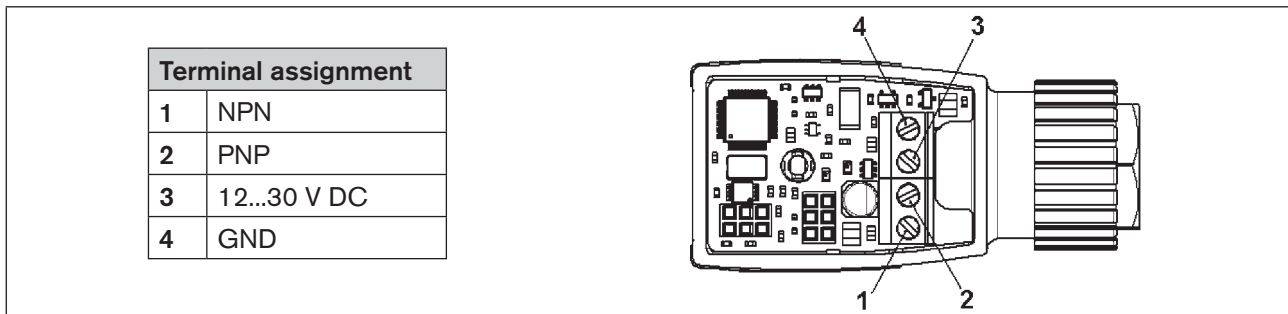

Fig. 2: Terminal assignment of a version with cable gland

#### 7.1.1 Using the device as a flow transmitter

##### NOTICE

- ▶ Switch off the device before removing the display unit or the transparent cover.
- ▶ Only power on the device when the cover is closed or when the display unit is screwed in place of the cover.

To use the device as a flow transmitter, do the following:

- Connect the 4...20 mA current output. Refer to [Fig. 3](#).
- Replace the device cover with a display unit. Tighten the screw to a torque of 0.2...0.3 N·m (0,15...0,22 lbf·ft), to not damage the housing.
- Energize the device.
- Choose the flow rate unit. Refer to chap. [8.5.1 Unit – Setting the unit for the flow rate](#).
- By default, the device output is configured to operate as a 4...20 mA current output. Set the flow rate range associated to the 4...20 mA current output. Refer to chap. [8.5.3 Out \(Output\) – Setting the output signal](#).
- Set the K factor of the fitting used. Refer to chap. [8.5.2 InP \(Input\) – Entering the K factor of the fitting or selecting a preset K factor](#).

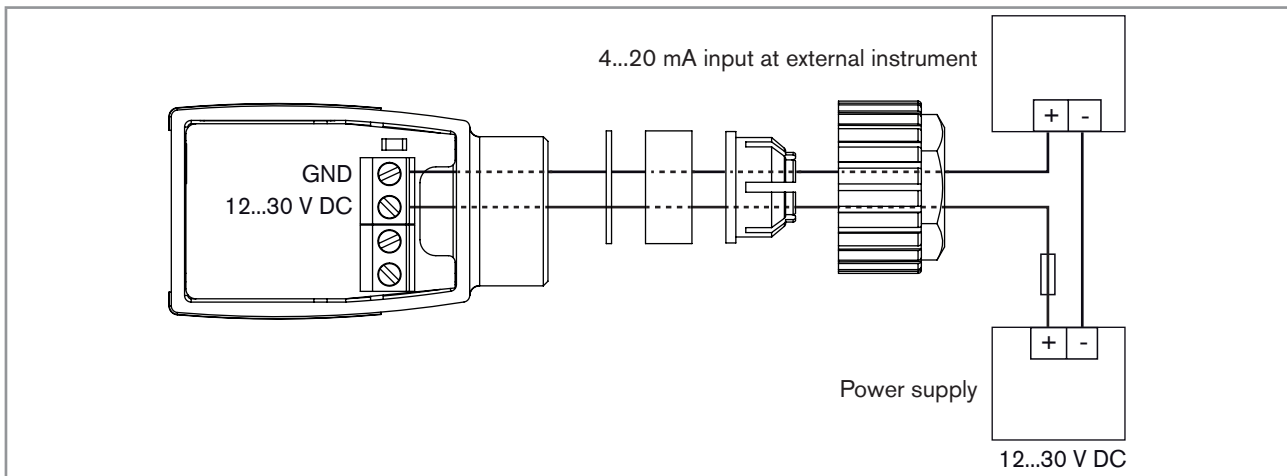

Fig. 3: Device with cable gland – Connection of the current output

→ De-energize the device.

→ Mount the device on a flow sensor. Refer to chap. [7.3](#).

## 7.1.2 Using the device as a pulse divider

### NOTICE

- ▶ Switch off the device before removing the display unit or the transparent cover.
- ▶ Only power on the device when the cover is closed or when the display unit is screwed in place of the cover.

To use the device as a pulse divider, do the following:

- Connect the transistor output. The transistor output can be connected in the following modes: NPN or PNP. Refer to [Fig. 4](#) or [Fig. 5](#).
- Replace the device cover with a display unit. Tighten the screw to a torque of 0.2...0.3 N·m (0,15...0,22 lbf·ft), to not damage the housing.
- Energize the device.
- By default, the device output is configured to operate as a 4...20 mA current output. To change the operating mode, change the settings of the device output. Refer to chap. [8.5.3 Out \(Output\) – Setting the output signal](#).
- Set the K factor of the fitting used. Refer to chap. [8.5.2 InP \(Input\) – Entering the K factor of the fitting or selecting a preset K factor](#).
- If you want to display the measured flow rate, choose the flow rate unit. Refer to chap. [8.5.1 Unit – Setting the unit for the flow rate](#).

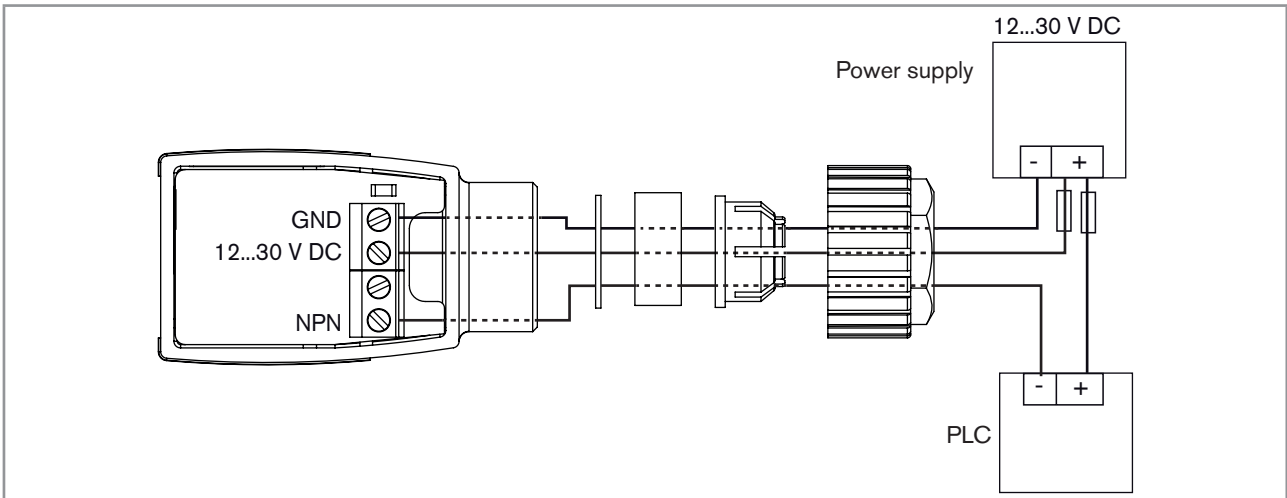

Fig. 4: Device with cable gland – NPN connection of the transistor output

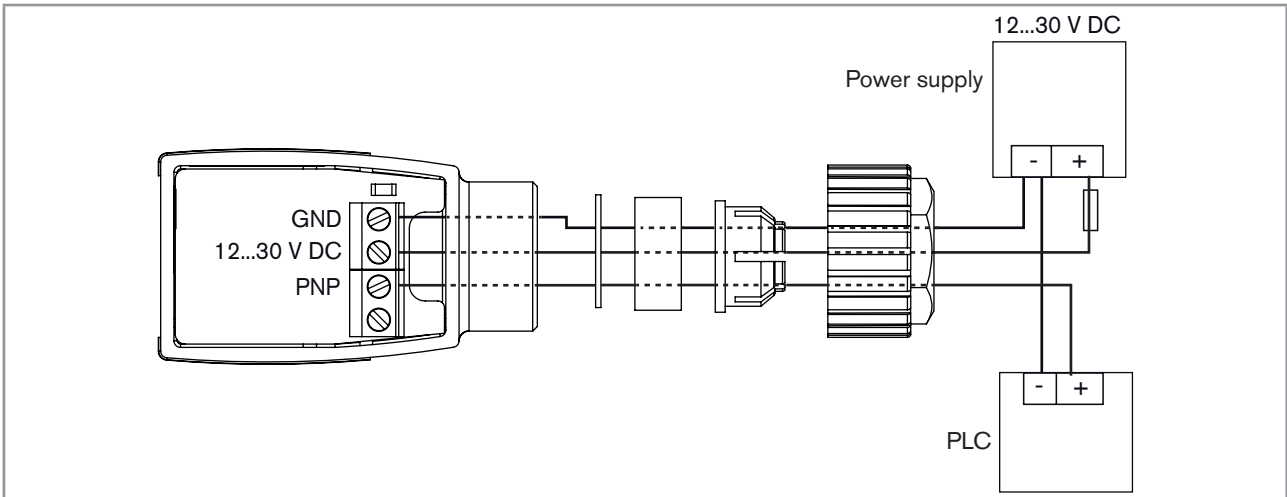

Fig. 5: Device with cable gland – PNP connection of the transistor output

→ De-energize the device.

→ Mount the device on a flow sensor. Refer to chap. 7.3.

## 7.2 Wiring a version with a 4-pin M12 male connector

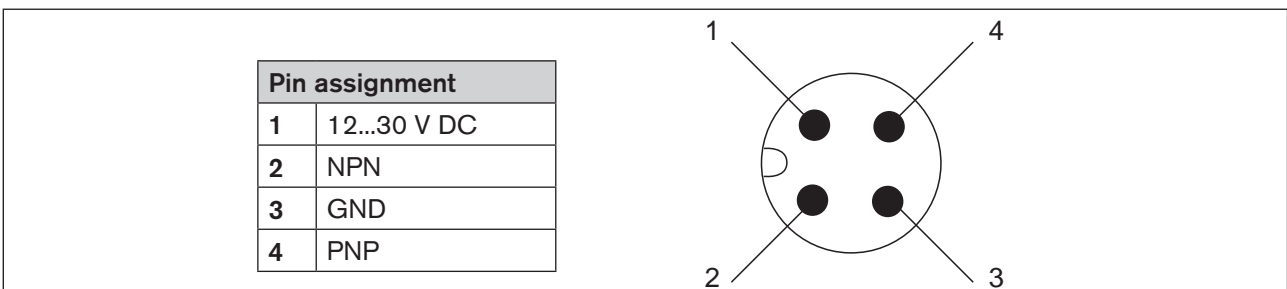

Fig. 6: Pin assignment of the 4-pin M12 male connector (version with M12 connector)

## 7.2.1 Using the device as a flow transmitter

### NOTICE

- ▶ Switch off the device before removing the display unit or the transparent cover.
- ▶ Only power on the device when the cover is closed or when the display unit is screwed in place of the cover.

To use the device as a flow transmitter, do the following:

- Connect the 4...20 mA current output. Refer to [Fig. 7](#).
- Replace the device cover with a display unit. Tighten the screw to a torque of 0.2...0.3 N·m (0,15...0,22 lbf·ft), to not damage the housing.
- Energize the device.
- Choose the flow rate unit. Refer to chap. [8.5.1 Unit – Setting the unit for the flow rate](#).
- By default, the device output is configured to operate as a 4...20 mA current output. Set the flow rate range associated to the 4...20 mA current output. Refer to chap. [8.5.3 Out \(Output\) – Setting the output signal](#).
- Set the K factor of the fitting used. Refer to chap. [8.5.2 InP \(Input\) – Entering the K factor of the fitting or selecting a preset K factor](#).

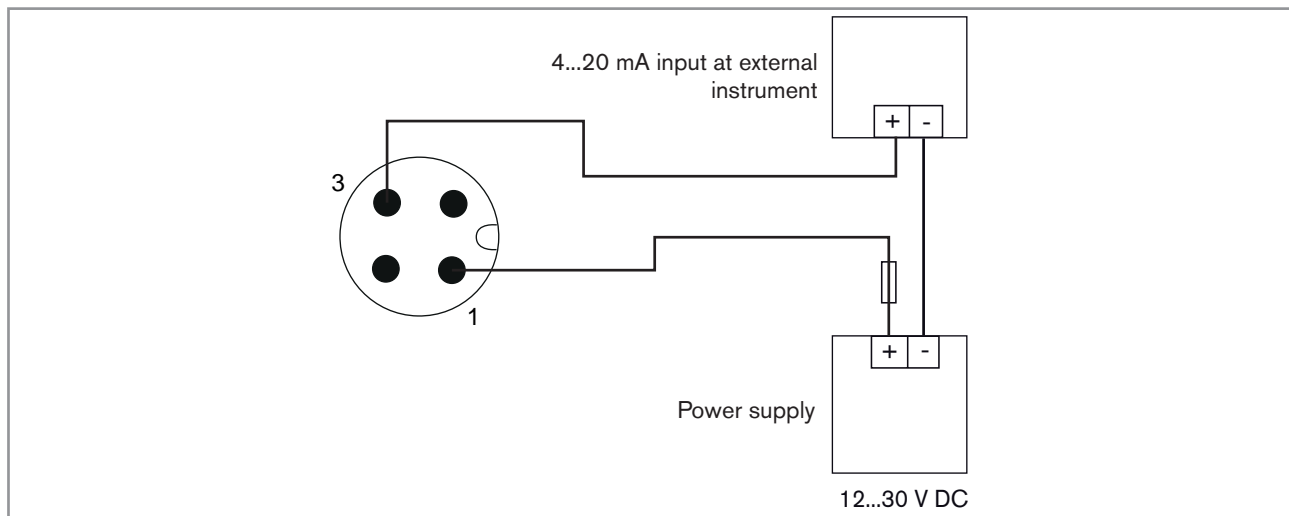

Fig. 7: Device with 4-pin M12 male connector – Connection of the current output

- De-energize the device.
- Mount the device on a flow sensor. Refer to chap. [7.3](#).

## 7.2.2 Using the device as a pulse divider

### NOTICE

- ▶ Switch off the device before removing the display unit or the transparent cover.
- ▶ Only power on the device when the cover is closed or when the display unit is screwed in place of the cover.



To use the device as a pulse divider, do the following:

- Connect the transistor output. The transistor output can be connected in the following modes: NPN or PNP. Refer to [Fig. 8](#) or [Fig. 9](#).
- Replace the device cover with a display unit. Tighten the screw to a torque of 0.2...0.3 N·m (0,15...0,22 lbf·ft), to not damage the housing.
- Energize the device.
- By default, the device output is configured to operate as a 4...20 mA current output. To change the operating mode, change the settings of the device output. Refer to chap. [8.5.3 Out \(Output\) – Setting the output signal](#).
- Set the K factor of the fitting used. Refer to chap. [8.5.2 InP \(Input\) – Entering the K factor of the fitting or selecting a preset K factor](#).
- If you want to display the flow rate, choose the flow rate unit. Refer to chap. [8.5.1 Unit – Setting the unit for the flow rate](#).

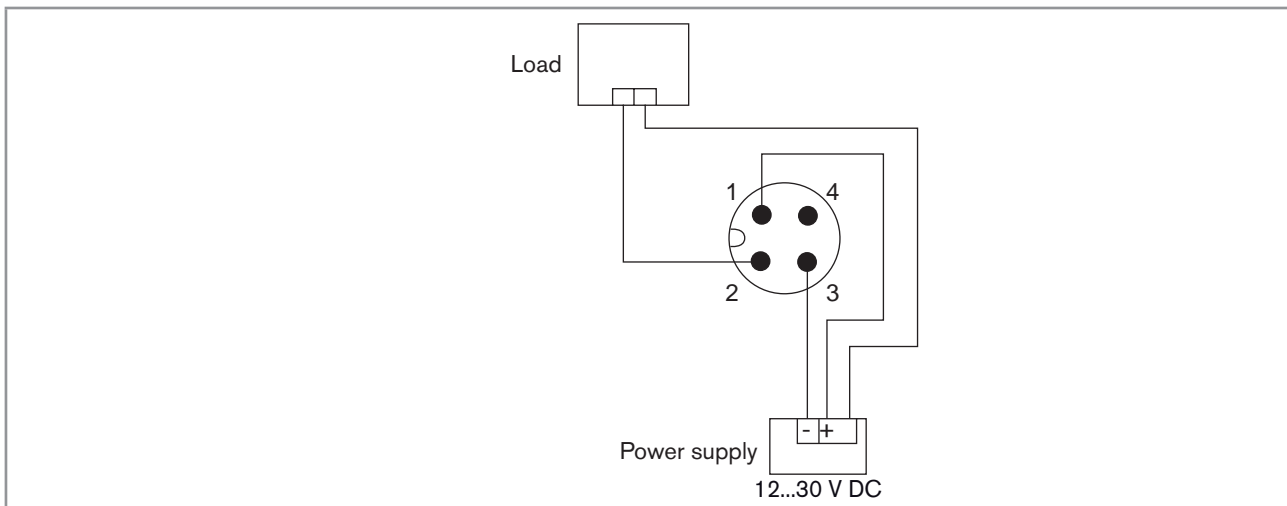

Fig. 8: Device with 4-pin M12 male connector – NPN connection of the transistor output

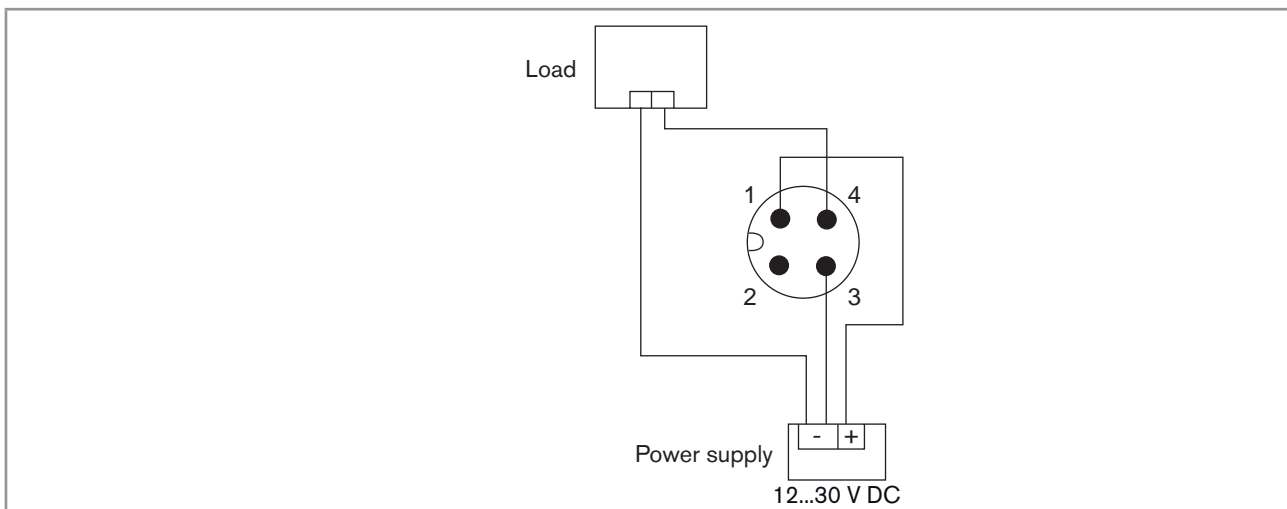

Fig. 9: Device with 4-pin M12 male connector – PNP connection of the transistor output

- De-energize the device.
- Mount the device on a flow sensor. Refer to chap. [7.3](#).

## 7.3 Mounting the device on a flow sensor

### NOTICE

- ▶ Switch off the device before removing the display unit or the transparent cover.
- ▶ Only power on the device when the cover is closed or when the display unit is screwed in place of the cover.

→ De-energize the device.

→ Insert the seal on the 4-pin male connector of the flow sensor.

→ Loosen the device screw.

→ Correctly position the device (see [Fig. 10](#)) and plug it on the 4-pin male connector of the flow sensor.

### NOTICE

**A faulty mounting can cause a faulty operation of the device.**

- ▶ When screwing the device to the sensor, make sure the seal is seated correctly.
- ▶ Tighten the screw to a torque of 0.2...0.3 N·m (0,15...0,22 lbf·ft), to not damage the housing.

→ Insert the screw through the cover or the display unit, the device housing, the seal and the flow sensor housing and tighten it to a torque of 0.2...0.3 N·m (0,15...0,22 lbf·ft). Make sure the seal is seated correctly.

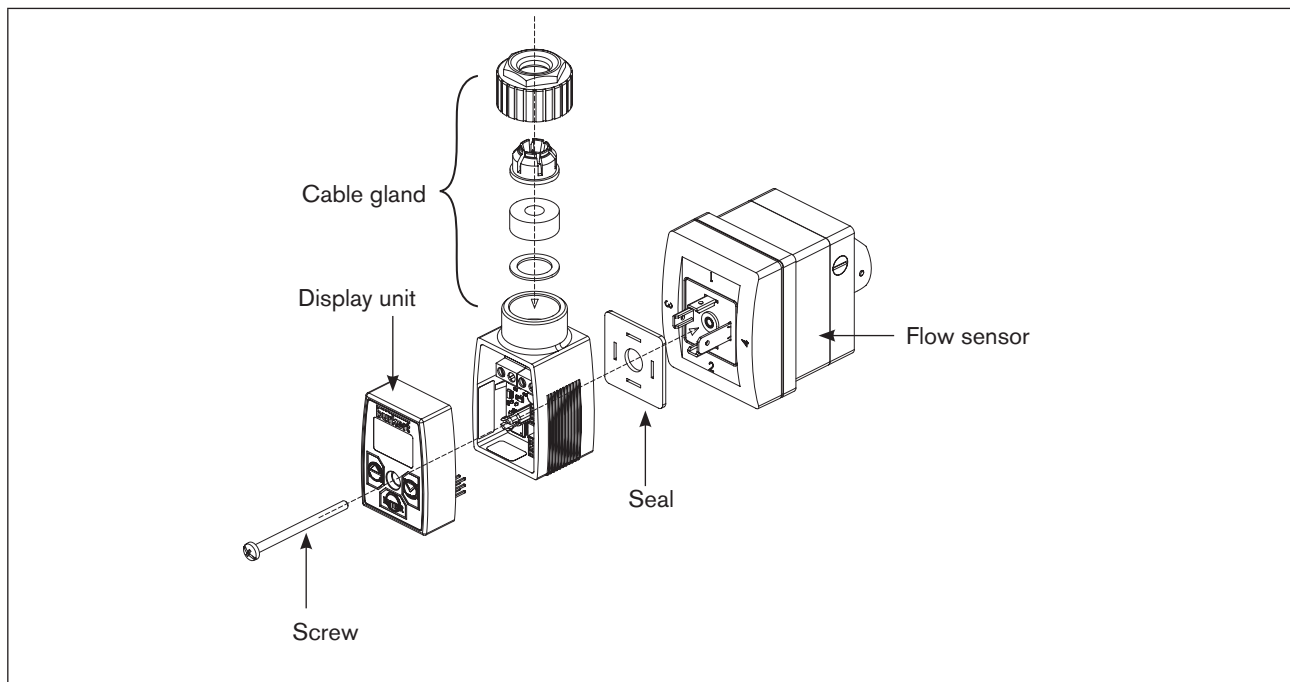

Fig. 10: Installing the device on the sensor (example of a device with cable gland and display unit, mounted on a Type SE30 sensor)

→ Install the combination made of the device and the sensor on or in a fitting which is already installed in the pipe.

## 8 ADJUSTMENT

### 8.1 Display unit

The display unit is required to indicate the flow rate or to configure the device. It can be removed after the settings have been made if you do not want to display the measured flow rate.

#### NOTICE

- ▶ Switch off the device before removing the display unit or the transparent cover.
- ▶ Only power on the device when the cover is closed or when the display unit is screwed in place of the cover.

#### NOTICE

**The device is not tight when the display unit is removed.**

- ▶ Screw the cover with article number 670549 on the device as soon as the display unit is removed.

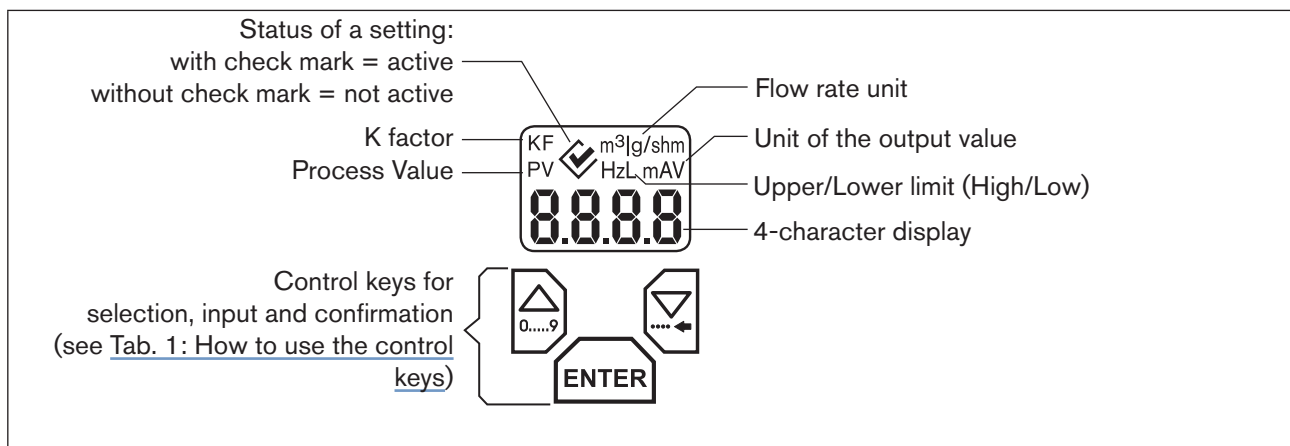

Fig. 11: Display unit

Operating level (see chapter 8.4 Operating levels)			
Level 1: Process level	Switching over the display value from: <ul style="list-style-type: none"> <li>▪ PV ProcessValue in set flow rate unit</li> <li>▪ PV ProcessValue in mA</li> <li>▪ PV ProcessValue in Hz (frequency of sensor)</li> </ul>		Press and hold for 3 s: Change to the configuration level
Level 2: Configuration level	Scroll up (select).	Scroll down (select).	Confirm parameter, change between parameters. Select and deselect parameter, confirm set values. Change to Process level when <i>End</i> is shown
	Enter values Increase numerical value by one value.		

Tab. 1: How to use the control keys

## 8.2 Operation as a flow transmitter

To operate the device as a flow transmitter, do the following settings:

- Set the K factor of the fitting used. Take the correct K factor value from the Operating Instructions of the fitting used. Always set the K factor in the pulse/liter unit. Refer to chap. [8.5.2](#).
- Choose the unit in which the measured flow rate values are displayed. The chosen unit is also applied to the limits of the flow rate range associated to the 4...20 mA current output. Refer to chap. [8.5.1](#).
- Enter the upper and lower limits of the flow rate range associated to the 4...20 mA signal. Refer to chap. [8.5.3](#).

## 8.3 Operation as a pulse divider

To operate the device as a pulse divider, do the following settings:

- Set the K factor of the fitting used. Take the correct K factor value from the Operating Instructions of the fitting used. Always set the K factor in the pulse/liter unit. Refer to chap. [8.5.2](#).
- Set the volume for each pulse sent out on the NPN and PNP outputs. A pulse is then sent out on the transistor output each time the set volume has been counted. Refer to chap. [8.5.3](#).

The frequency value of the flow sensor is converted via the K factor and the volume set for a pulse.

## 8.4 Operating levels

For operating the device there are 2 levels available: the process level and the configuration level.

### Level 1: Process level

When the device is switched on, it is at the Process level. The flow rate measured by the combined sensor is indicated.

At this level use the arrow keys to successively read different values and define which of them stays displayed. The values differ depending whether the device is operating as a flow transmitter or a pulse divider.



Flow transmitter	Pulse divider
 <div style="display: flex; flex-direction: column; gap: 10px;"> <div>PV <math>l/m</math> 25.5 Flow rate in liters/minute</div> <div>PV Hz 25.5 Input frequency of the flow rate sensor [Hz]</div> <div>PV mA 12.3 Output current [mA]</div> </div>	 <div style="display: flex; flex-direction: column; gap: 10px;"> <div>PV <math>l/m</math> 25.5 Flow rate in liters/minute</div> <div>PV Hz 25.5 Input frequency of the flow rate sensor [Hz]</div> </div>

Fig. 12: Level 1: Display options when operating as a flow transmitter or a pulse divider

**Level 2: Configuration level**

At this level, the settings for the device are made.

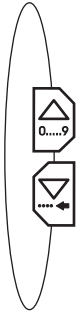
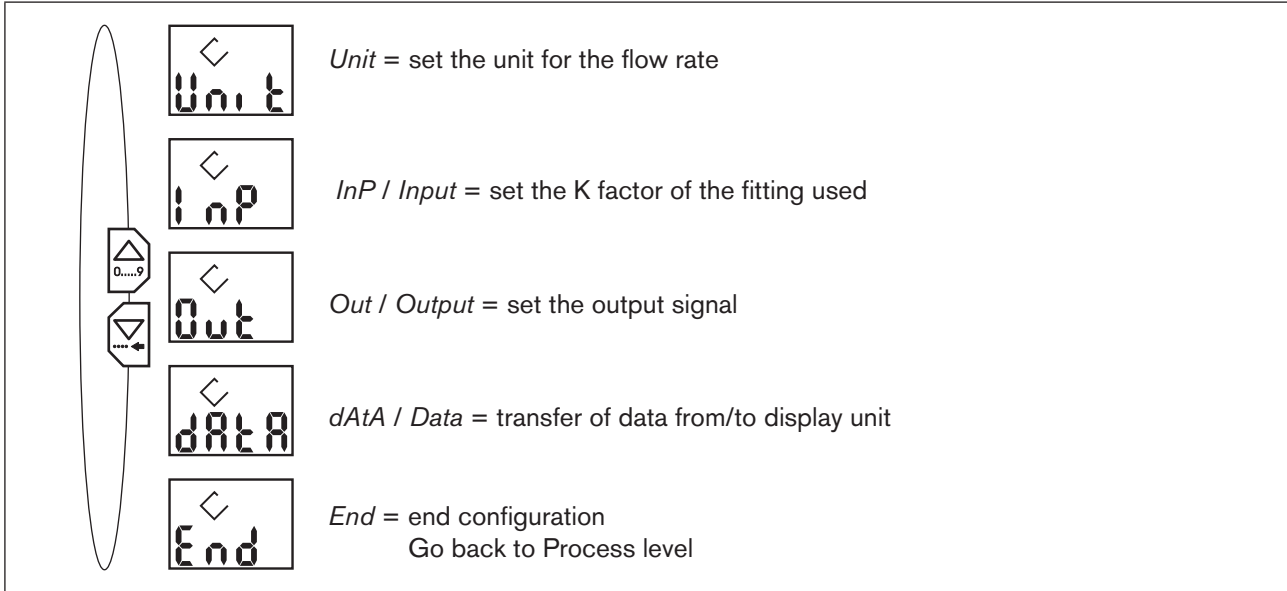

Fig. 13: Level 2: Define the settings

**8.4.1 Switching between the operating levels**

When the device is switched on, it is at the Process level.

→ Press and hold the ENTER key (3 seconds) to switch to the configuration level.

→ Confirm *End* in the main menu loop using the ENTER key to return to the Process level.

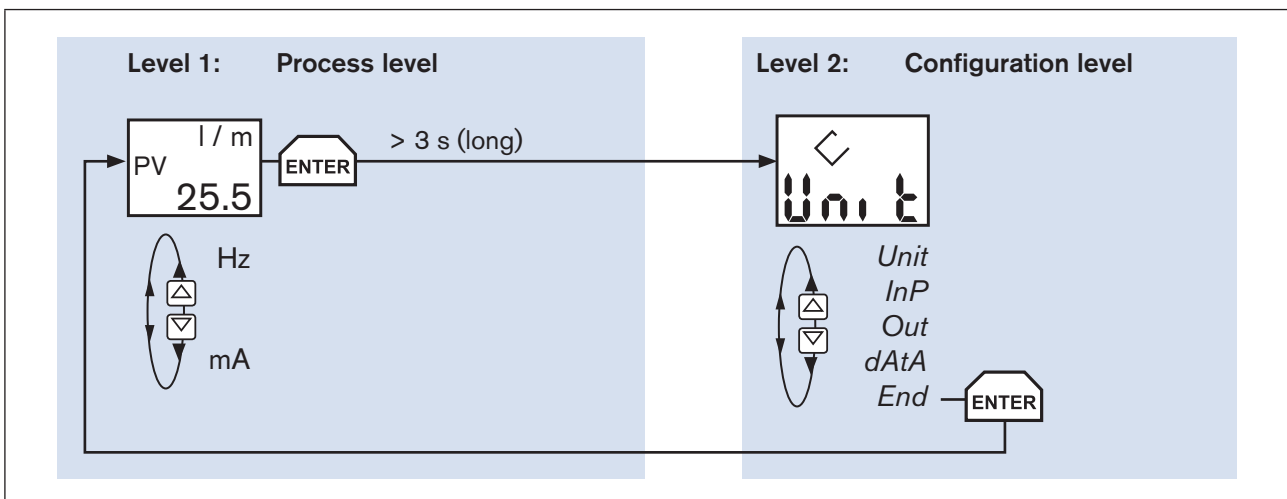

Fig. 14: Switching between the operating levels

## 8.5 Main menu of the configuration level

→ In the Process level, press and hold the ENTER key (3 s) to access the configuration level.

The following settings are possible:

Unit	Unit = set the unit for the flow rate, see chapter <a href="#">8.5.1</a>
InP	InP / Input = set the K factor of the fitting used, see chapter <a href="#">8.5.2</a>
Out	Out / Output = set the output signal, see chapter <a href="#">8.5.3</a>
dAtA	dAtA / Data = transfer of data from/to the display unit, see chapter <a href="#">8.5.4</a>

Leaving the configuration level:

End	End = end the settings and go back to the Process level by pressing the ENTER key when End is displayed.
-----	--

### 8.5.1 Unit – Setting the unit for the flow rate

In this parameter, set the unit the measured flow rate is displayed in and in which the limits of the flow rate range associated to the 4...20 mA output are defined.



When changing the unit (e.g. from liters to gallons), also change the current output limits.

Setting in the parameter:

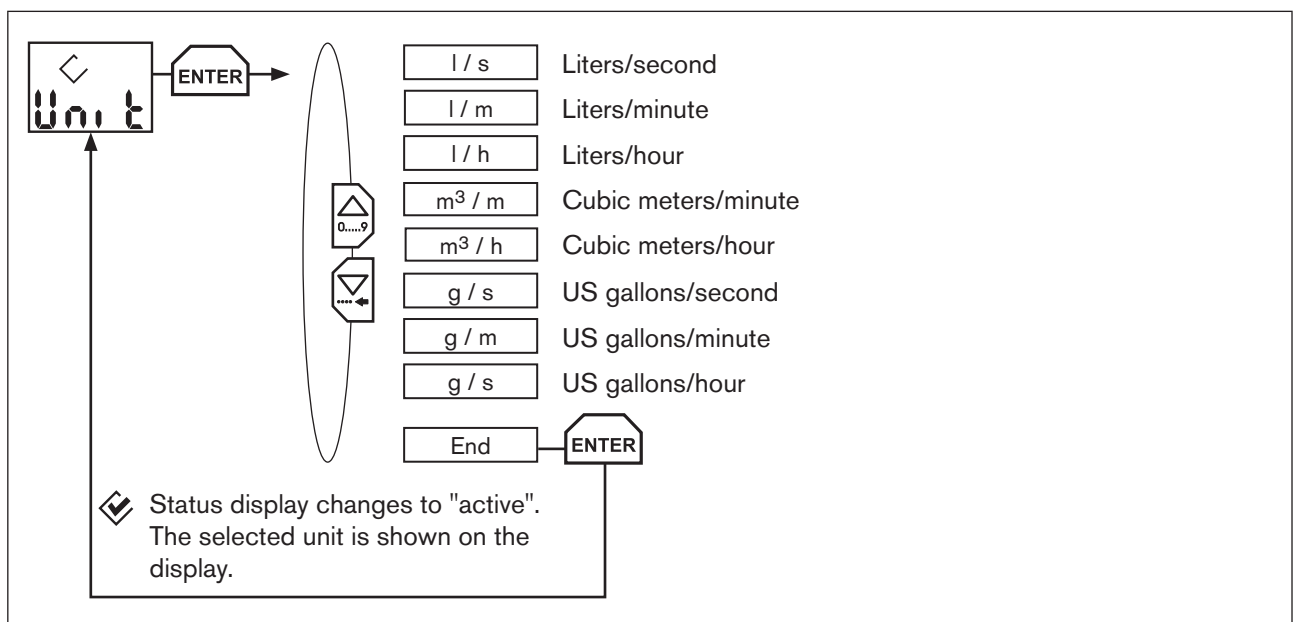

Fig. 15: Unit – Setting the display for the flow rate unit

## 8.5.2 InP (Input) – Entering the K factor of the fitting or selecting a preset K factor

### Entering the value of the K factor:

- Go to the InP parameter and confirm.
- Go to the FrEE parameter and confirm.
- Enter the K factor of the fitting used, in pulses/liter. Refer to the Operating Instructions of the fitting used for the value of the K factor (for example type S020, S030, S070 or S077).
- Confirm the set K factor: the device uses the entered K factor.

### Selecting a preset K factor (available from “Version 2” of the device. Refer to the name plate):

The K factor values of the fittings S020, S030, S070 and S077 are preset in the device.

If you use	Instructions for selecting the correct preset K factor
<ul style="list-style-type: none"> <li>▪ a fitting type S020 with a sensor type 8020</li> </ul>	<ul style="list-style-type: none"> <li>→ Go to the InP parameter and confirm.</li> <li>→ Go to the menu 8020 and confirm.</li> <li>→ Go to the fitting model, for example SAdd if you use a saddle, and confirm.</li> <li>→ Go to the material the fitting is made of and confirm.</li> <li>→ Go to the DN of the fitting. Confirm: the preset K factor is displayed. Check that the displayed K factor is the same as the one indicated in the Operating Instructions of the fitting used.</li> <li>→ Confirm. The status display changes to “active”.</li> <li>☑ The preset K factor is used by the device.</li> </ul>
<ul style="list-style-type: none"> <li>▪ a fitting type S030 with a sensor type 8030 or SE30</li> </ul>	<ul style="list-style-type: none"> <li>→ Go to the InP parameter and confirm.</li> <li>→ Go to the menu 8030 and confirm.</li> <li>→ Go to the material the fitting is made of and confirm.</li> <li>→ Go to the DN of the fitting. Confirm: the preset K factor is displayed. Check that the displayed K factor is the same as the one indicated in the Operating Instructions of the fitting used.</li> <li>→ Confirm. The status display changes to “active”.</li> <li>☑ The preset K factor is used by the device.</li> </ul>
<ul style="list-style-type: none"> <li>▪ a fitting type S070 or a fitting type S077, with a sensor type SE30</li> </ul>	<ul style="list-style-type: none"> <li>→ Go to the InP parameter and confirm.</li> <li>→ Go to the menu 8070 and confirm.</li> <li>→ Go to the DN of the fitting. Confirm: the preset K factor is displayed. Check that the displayed K factor is the same as the one indicated in the Operating Instructions of the fitting used.</li> <li>→ Confirm. The status display changes to “active”.</li> <li>☑ The preset K factor is used by the device.</li> </ul>

Parameters available from a "Version 2" of the device. Refer to the name plate of the device.

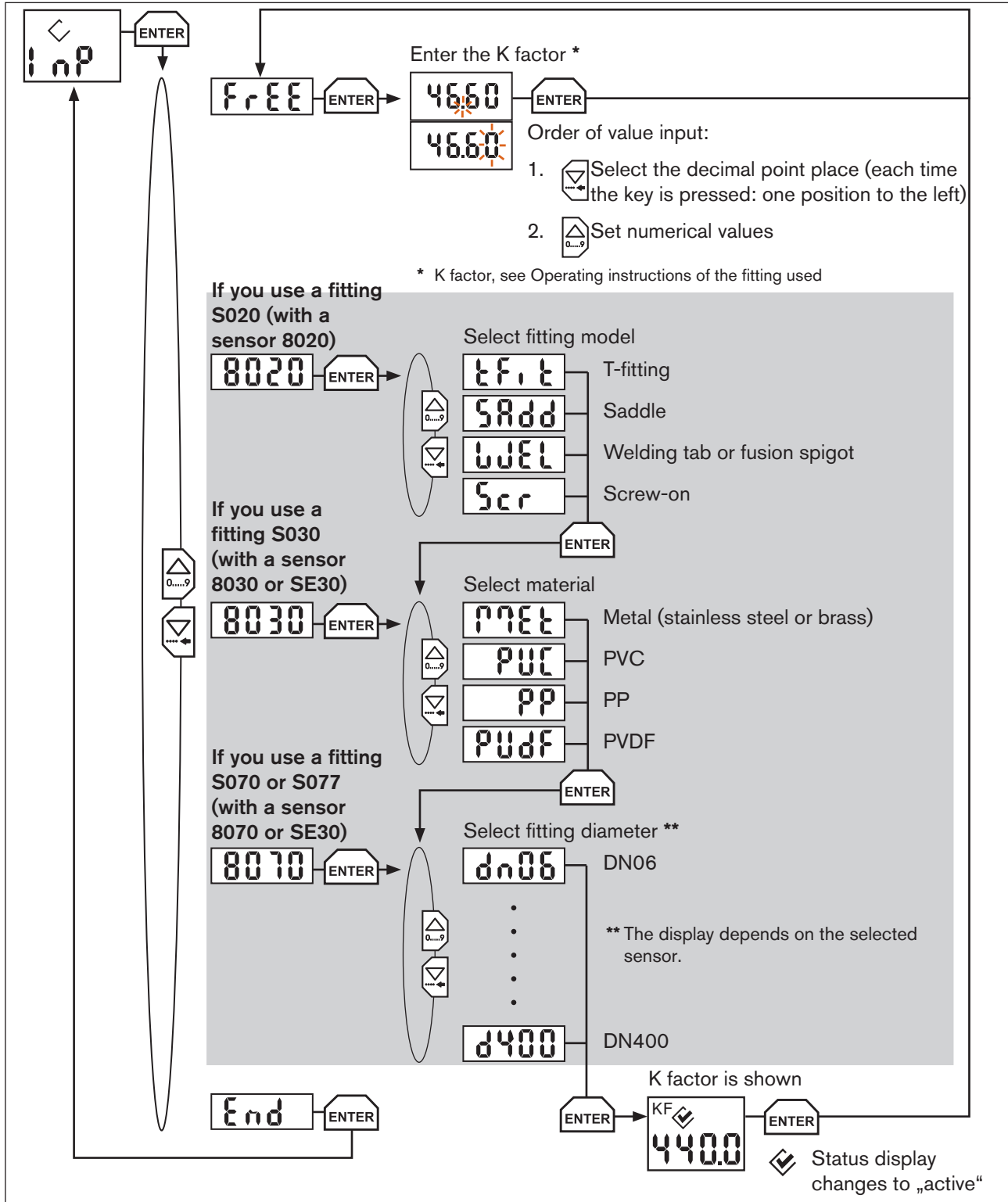

MAN 1000217540 EN Version: D Status: RL (released | freigegeben) printed: 11.01.2019

Fig. 16: Input – Setting the K factor



### 8.5.3 Out (Output) – Setting the output signal

In this parameter, define whether the device is to work as a flow transmitter or a pulse divider.

#### Setting as flow transmitter (4 - 20 mA):



When changing the unit (e.g. from liters to gallons) the limit values for the current output are not converted automatically

→ Set the lower and upper limit values for the flow rate range associated to the 4...20 mA output, in the unit set within the UNIT parameter.

The lower limit value is marked by an L (low) on the display and the upper limit value by an H (high).

#### Setting as pulse divider (Freq):

→ Set the volume, in the displayed unit, for each pulse emitted on the NPN and PNP outputs.

Setting in the parameter:

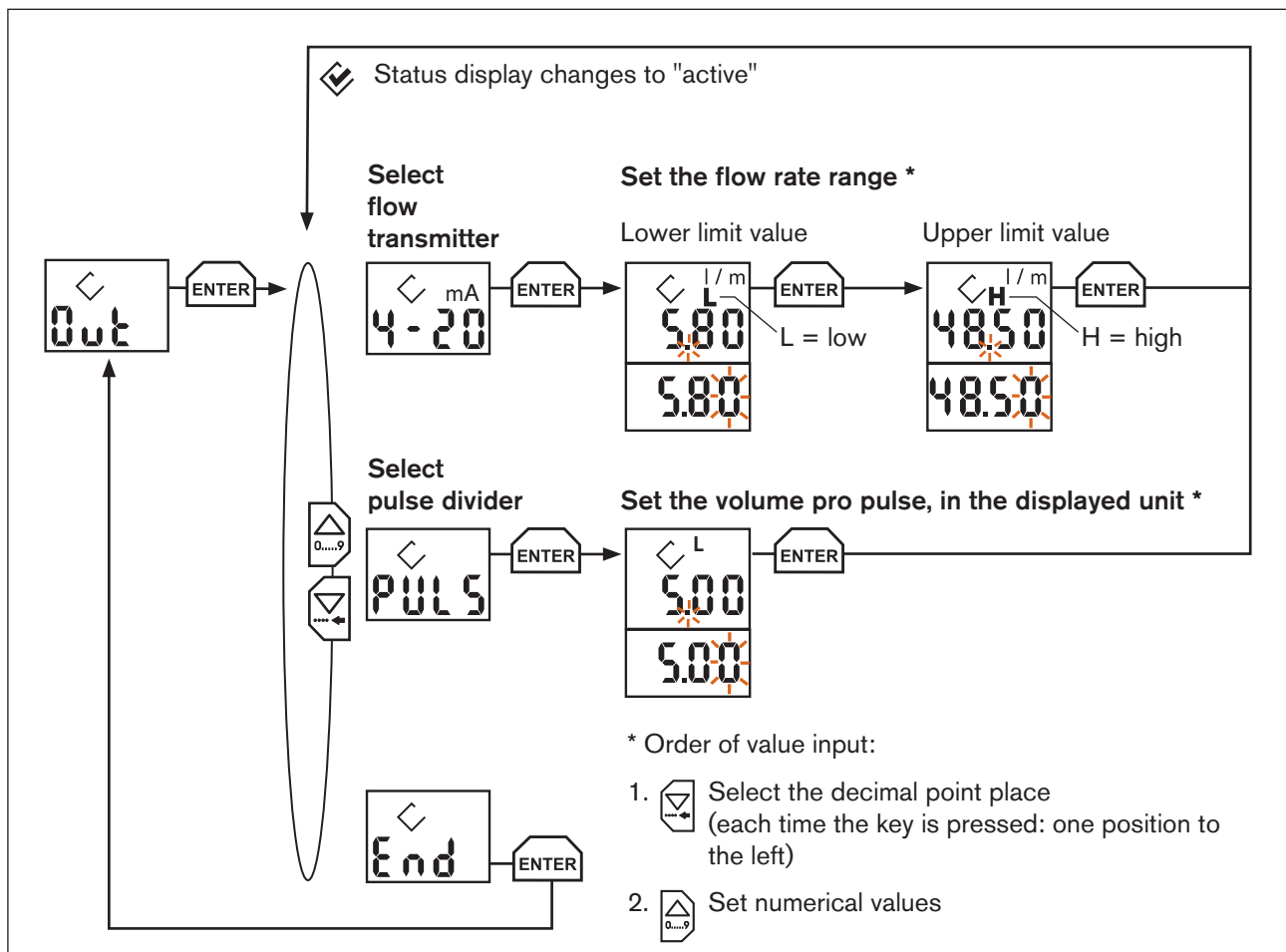

Fig. 17: Out – Setting the output; operation as flow transmitter or pulse divider

### 8.5.4 dAtA (Data) – Uploading and downloading the device settings

This function is available from the “Version 2” of the device. Refer to the name plate of the device.

The parameter makes it possible to transfer the device settings from one device to another device which have the same software version number.

→ To read the software version number of the device, restart the device. The software version number is displayed for 1 s.

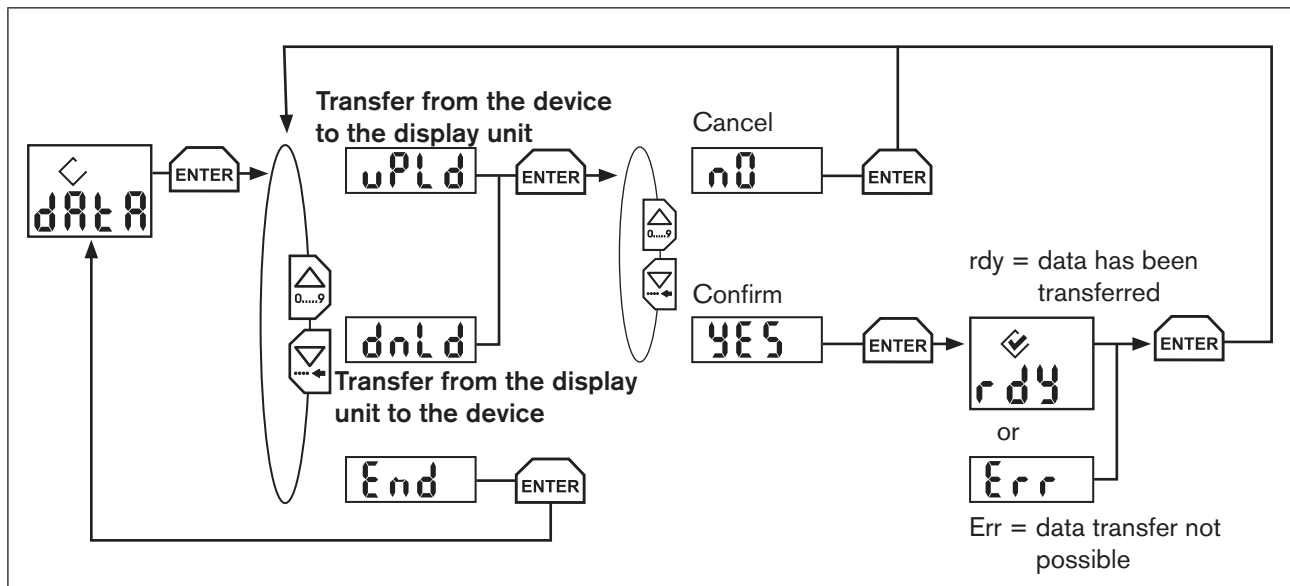

Fig. 18: Data – Transfer of data from/to display unit

To transfer the device settings to another device, do the following:

- Make sure both devices have the same software version number.
- De-energize the 2 devices.
- Install the display unit on the device whose configuration is to be duplicated.
- Energize the device.
- Go to the configuration level.

→ dAtA. Confirm.

→ uPLd. Confirm.

→ yES. Confirm.

✓ If the display shows **rdY**, the device configuration has been successfully transferred from the device to the display unit.

If the display shows **Err**, the device configuration could not be written in the display unit memory. Contact the Bürkert service.

→  Confirm to go back to the parent menu.

→ De-energize the device.

→ Remove the display unit and install it on the device to be configured.

→ Energize the device.

→ Go to the configuration level.

→  **dAtA.**  Confirm.

→  **dnLd.**  Confirm.

→  **yES.**  Confirm.

✓ If both devices have the same software version number and the display shows **rdY**, the configuration has been successfully transferred from the display unit to the device.

If the display shows **Err**, the device configuration could not be read from the display unit memory. Contact the Bürkert service.

→  Confirm to go back to the parent menu.

## 9 MAINTENANCE, TROUBLESHOOTING

### 9.1 Maintenance work

The device is maintenance-free when operated according to these Operating Instructions.

### 9.2 Error messages

Error messages are only displayed at the Process level. They are shown alternately (flashing) with the process value.

Error	Cause	Troubleshooting
ERR1	Value cannot be displayed (e.g. value too high).	<ul style="list-style-type: none"> <li>Change the flow rate unit (see chapter <a href="#">8.5.1 Unit – Setting the unit for the flow rate</a>).</li> </ul>
ERR2	Input frequency of sensor higher than 600 Hz.	<ul style="list-style-type: none"> <li>Use a suitable sensor.</li> </ul>
ERR3	Calculated output current not within range of 4...20 mA or K factor = 0.	<ul style="list-style-type: none"> <li>Correctly set the flow rate range associated to the 4...20 mA current output.</li> <li>Use a different sensor and/or correctly set the K factor of the fitting used.</li> </ul>
ERR4	Limit values of the flow rate range associated to the 4...20 mA current output not correct (Low > High).	Correctly set the values.
ERR5	The K factor times the set volume (converted in liters) pro pulse is < 1.	<ul style="list-style-type: none"> <li>Check the set K factor.</li> <li>If the K factor is correct, enter a higher volume pro pulse so that the K factor times the set volume (converted in liters) pro pulse is equal to or higher than 1.</li> </ul>

Tab. 2: Error messages

### 9.3 Default values

Upon delivery, the following default values are saved:

Parameter	Value
Unit	Liters/second [l/s]
K factor (of fitting used)	1 pulse/liter [imp/l]
Volume pro pulse	1 liter
Output signal (OUT)	4...20 mA
Lower flow rate limit	0 liters/second [l/s]
Upper flow rate limit	250 liters/second [l/s]

Tab. 3: Default values

## 10 ACCESSORIES

Accessory	Article number
Display unit	562 876
Transparent cover, with screw and seal (for operating without display unit)	670 549
4-pin M12 female right-angle connector	784 301
4-pin M12 female connector moulded on 5-m long cable	918 038

Tab. 4: Ordering table of spare parts and accessories

## 11 PACKAGING AND TRANSPORT

### NOTICE

#### Transport damage!

Inadequately protected equipment may be damaged during transport.

- During transportation protect the device against moisture and dirt in shock-resistant packaging.
- Do not allow the temperature to exceed or drop below the permitted storage temperature.

## 12 STORAGE

### NOTICE

#### Incorrect storage may damage the device.

- Store the device in a dry and dust-free location!
- Storage temperature: -20...+65 °C

## 13 DISPOSAL

→ Dispose of the device and packaging in an environmentally friendly manner.



Observe national waste disposal regulations.





