



## Servo-assisted 2-way high-flow solenoid control valve

- Control valve for continuous control of liquids
- Low hysteresis and high repeatability
- Control with PWM signal
- Servo-assisted, tight closing valve



Product variants described in the data sheet may differ from the product presentation and description.

### Can be combined with

	<b>Type 2518</b> Cable Plug DIN EN 175301-803 - Form A	▶
	<b>Type 8605</b> PWM Control Electronics for Solenoid Control Valves	▶

### Type description

The valve Type 6223 can be used for the control of larger flow quantities. Low hysteresis, high reproducibility and good response sensitivity guarantee good positioning behaviour. The valve closes tight. The push-over coil is easy to replace.

## Table of contents

<b>1. General Technical Data</b>	<b>3</b>
<b>2. Circuit functions</b>	<b>3</b>
<b>3. Materials</b>	<b>4</b>
3.1. Chemical Resistance Chart – Bürkert resistApp.....	4
<b>4. Dimensions</b>	<b>4</b>
4.1. DN10 version with coil size 5.....	4
4.2. DN13 version with coil size 6.....	5
4.3. DN20 version with coil size K.....	6
<b>5. Performance specifications</b>	<b>7</b>
5.1. Flow characteristic.....	7
Determination of the $K_v$ value.....	7
5.2. Exemplary characteristic curve of a proportional valve.....	7
<b>6. Ordering information</b>	<b>8</b>
6.1. Bürkert eShop – Easy ordering and quick delivery.....	8
6.2. Recommendation regarding product selection.....	8
6.3. Bürkert product filter.....	8
6.4. Ordering chart.....	8
6.5. Ordering chart accessories.....	9
Cable plug Type 2518, Form A according to DIN EN 175301 - 803.....	9
Control unit Type 8605.....	9

## 1. General Technical Data

Product properties	
Dimensions	Detailed information can be found in chapter "4. Dimensions" on page 4.
Material	
Body	Brass, stainless steel on request
Seal	FKM, others on request
Performance data	
Typical values of positioning behaviour <sup>1.)</sup>	
Hysteresis	< 5 %
Reproducibility	< 1 % of end value <sup>2.)</sup>
Response sensitivity	< 1 % of end value <sup>2.)</sup>
Setting range	1:10
Actuating time (10...90 %)	< 200 ms
Pressure range <sup>3.)</sup>	0,5...10 bar
Nominal operating mode	100 % continuous operation
Electrical data	
Operating voltage	24 V DC (12 V on request)
Power consumption	Detailed information can be found in chapter "6.4. Ordering chart" on page 8.
Maximum coil current <sup>4.)</sup>	Detailed information can be found in chapter "6.4. Ordering chart" on page 8.
PWM frequency <sup>5.)</sup>	280 Hz
Medium data	
Medium	Neutral liquids
Medium temperature	- 10 °C...+ 90 °C
Viscosity (max.)	Maximum 21 mm <sup>2</sup> /s (21 cSt)
Process/Port connection & communication	
Port connection size	G 3/8, G 1/2, G 3/4, G 1
Electrical connection	Cable plug Type 2518 acc. to DIN EN 175301 - 803 form A Detailed information can be found in chapter "Cable plug Type 2518, Form A according to DIN EN 175301 - 803" on page 9.
Approvals and certificates	
Degree of protection	IP65
Environment and installation	
Installation position	Any, preferably actuator face up
Ambient temperature	Maximum + 55 °C

1.) Characteristic data of control behaviour depends on process conditions.

2.) By flow measurement

3.) Pressure data: Overpressure with respect to atmospheric pressure, depending on nominal diameter, tightness seal or nominal pressure

4.) Maximum value: value depends on operating pressure

5.) PWM: pulse width modulation

## 2. Circuit functions

Circuit functions	Description
	<b>Type: A, proportional control valve</b> 2/2 way Direct-acting Normally closed

### 3. Materials

#### 3.1. Chemical Resistance Chart – Bürkert resistApp

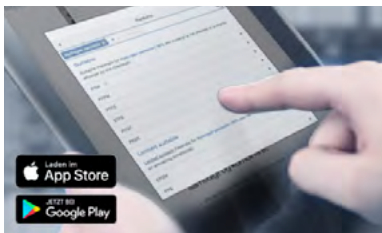

**Bürkert resistApp – Chemical Resistance Chart**

You want to ensure the reliability and durability of the materials in your individual application case? Verify your combination of media and materials on our website or in our resistApp.

[Start Chemical Resistance Check](#)

### 4. Dimensions

#### 4.1. DN10 version with coil size 5

**Note:**  
Dimensions in mm

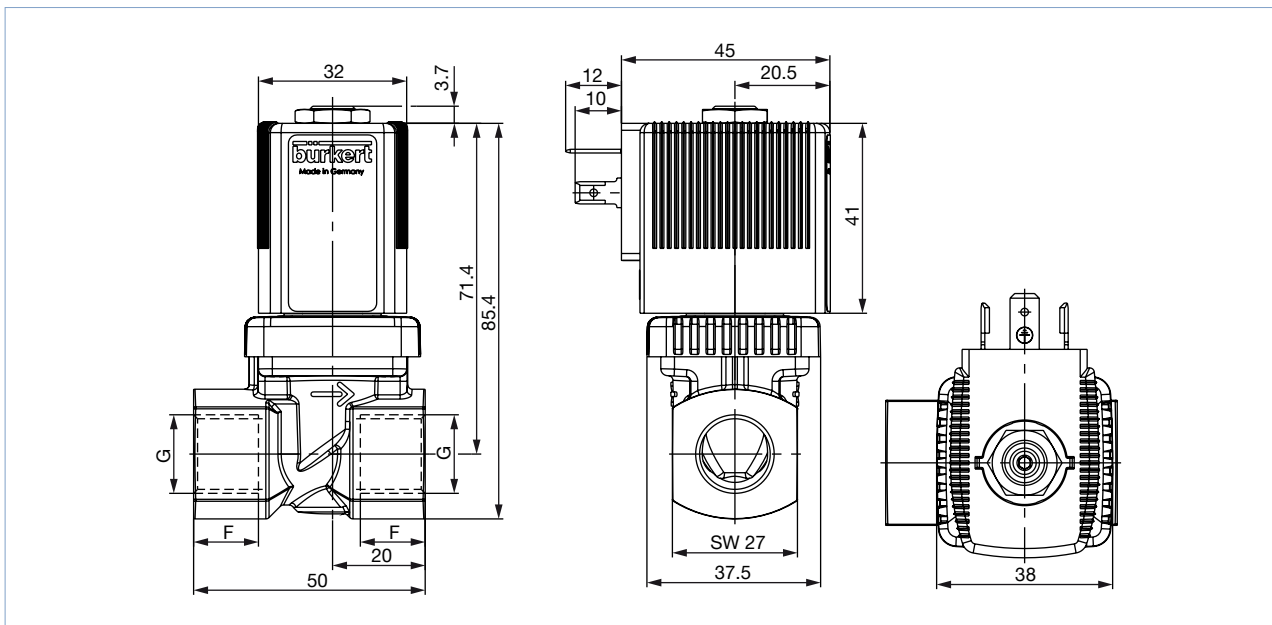

DN	F1	G1	F2	G2	F3	G3
DN10	12	G 3/8	10.3	NPT 3/8	10.1	Rc 3/8
	14	G 1/2	13.7	NPT 1/2	13.2	Rc 1/2

DTS 1000011057 EN Version: K Status: RL (released | freigegeben | validé) printed: 26.03.2021

4.2. DN13 version with coil size 6

**Note:**  
Dimensions in mm

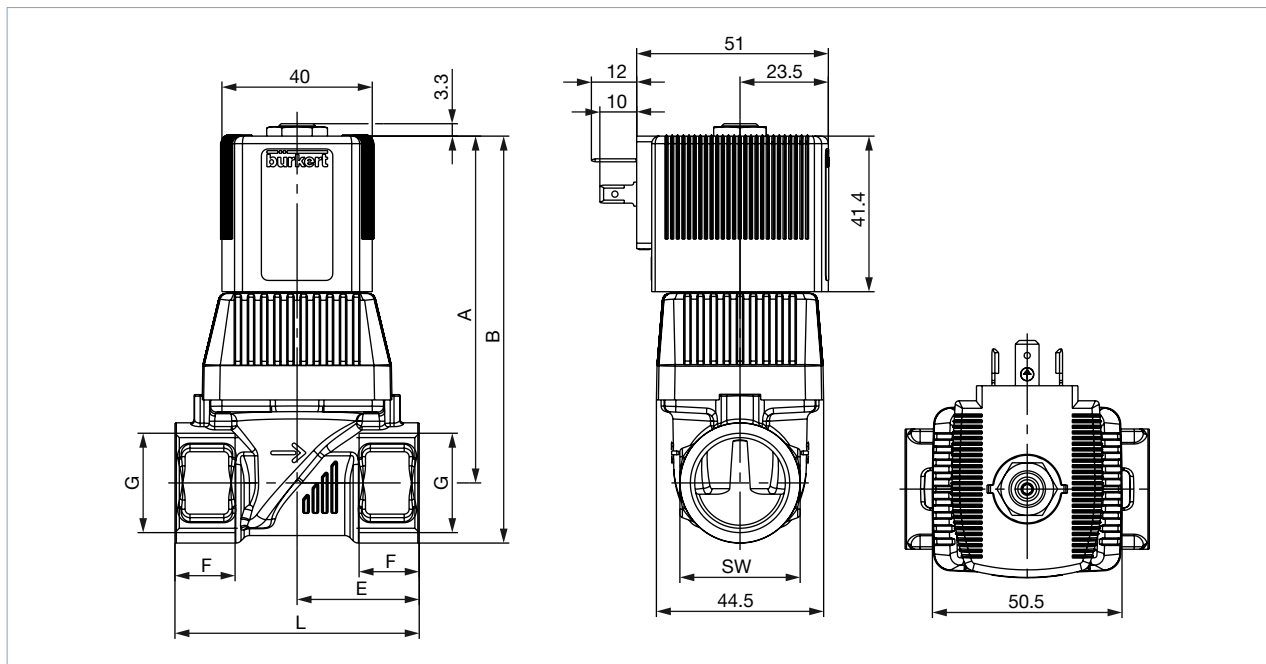

DN	A	B	E (MS/VA)	F1	G1	F2	G2	F3	G3	L (MS/VA)	SW
DN13	90.3	103.8	27.25/32.5	14	G 1/2	13.7	NPT 1/2	13.2	Rc 1/2	58/65	27
	92.3	108.3	32.5	16	G 3/4	14	NPT 3/4	14.5	Rc 3/4	65	32

DTS 1000011057 EN Version: K Status: RL (released | freigegeben | valide) printed: 26.03.2021

4.3. DN20 version with coil size K

**Note:**

Dimensions in mm

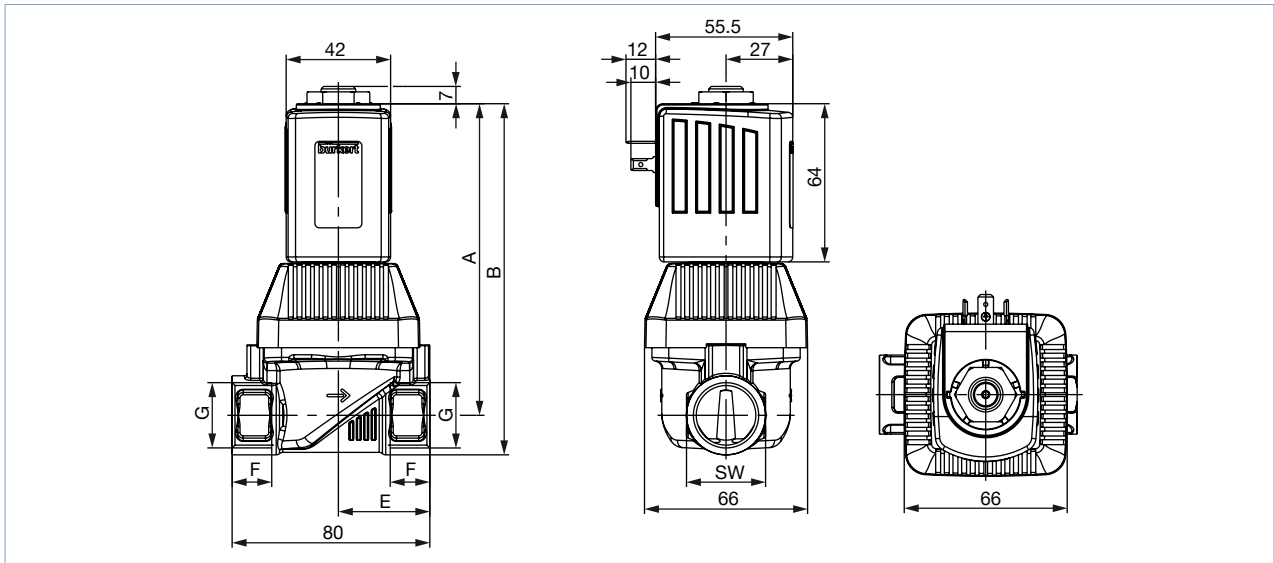

DN	A	B	E	F1	G1	F2	G2	F3	G3	SW
DN20	126.1	142.1	37	16	G 3/4	14	NPT 3/4	14.5	Rc 3/4	32
	128.6	149.1	37.5	18	G 1	16.8	NPT 1	16.8	Rc 1	41

## 5. Performance specifications

### 5.1. Flow characteristic

#### Determination of the $K_V$ value

Pressure drop	$K_V$ value for liquids	$K_V$ value for gases
	[m <sup>3</sup> /h]	[m <sup>3</sup> /h]
Sub-critical $p_2 > \frac{p_1}{2}$	$= Q \sqrt{\frac{\rho}{1000 \Delta p}}$	$= \frac{Q_N}{514} \sqrt{\frac{T_1 \rho_N}{p_2 \Delta p}}$
Supercritical $p_2 < \frac{p_1}{2}$	$= Q \sqrt{\frac{\rho}{1000 \Delta p}}$	$= \frac{Q_N}{257 p_1} \sqrt{T_1 \rho_N}$

$K_V$ Flow coefficient	[m <sup>3</sup> /h] <sup>1)</sup>
$Q_N$ Standard flow rate	[m <sup>3</sup> /h] <sup>2)</sup>
$p_1$ Inlet pressure	[bar] <sup>3)</sup>
$p_2$ Outlet pressure	[bar] <sup>3)</sup>
$\Delta p$ Differential pressure $p_1 - p_2$	[bar]
$\rho$ Density	[kg/m <sup>3</sup> ]
$\rho_N$ Standard density	[kg/m <sup>3</sup> ]
$T_1$ Medium temperature	[(273+t)K]

- 1.) Measured for water,  $\Delta p = 1$  bar, over the valve
- 2.) At reference conditions 1.013 bar and 0 °C (273 K)
- 3.) Absolute pressure

### 5.2. Exemplary characteristic curve of a proportional valve

#### Note:

In continuous flow applications, the choice of an appropriate valve size is much more important than with on/off valves. The optimum size should be selected such that the resulting flow in the system is not unnecessarily reduced by the valve. However, a sufficient part of the pressure drop should be taken across the valve even when it is fully opened.

Recommended value:  $\Delta p_{\text{valve}} > 25\%$  of total pressure drop within the system

Otherwise, the ideal, linear valve curve characteristic is changed.

If the differential pressure (difference between inlet and outlet pressure) exceeds half the value of the nominal pressure discontinuities may occur.

For that reason take advantage of Bürkert competent engineering services during the planning phase!

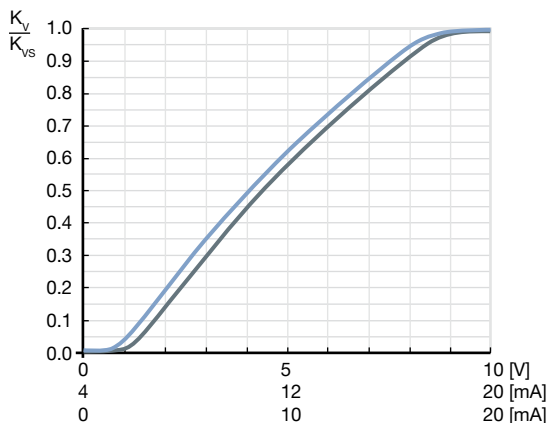

## 6. Ordering information

### 6.1. Bürkert eShop – Easy ordering and quick delivery



**Bürkert eShop – Easy ordering and fast delivery**

You want to find your desired Bürkert product or spare part quickly and order directly? Our online shop is available for you 24/7. Sign up and enjoy all the benefits.

[Order online now](#)

### 6.2. Recommendation regarding product selection

**Note:**

- Please use the **“Product Inquiry Form”** at the end of this data sheet for the specifications of the device configuration and send us a copy of the inquiry with information about the application.
- Please note the chapter **“5.2. Exemplary characteristic curve of a proportional valve”** on page 7 on product selection.

### 6.3. Bürkert product filter



**Bürkert product filter – Get quickly to the right product**

You want to select products comfortably based on your technical requirements? Use the Bürkert product filter and find suitable articles for your application quickly and easily.

[Try out our product filter](#)

### 6.4. Ordering chart

**Note:**

- All valves with FKM seal
- Please note that the cable plug must be ordered separately, see **“Cable plug Type 2518, Form A according to DIN EN 175301-803”** on page 9 or separate data sheet for **Type 2518** ▶.

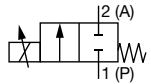
Circuit function	Orifice	Port con- nection	K <sub>vs</sub> value water <sup>1.)</sup>	Pressure range <sup>2.)</sup>	Maximum coil current	Power con- sumption	Article no. stainless steel body
	[mm]						
<b>A, proportional control valve</b> 2/2 way Direct-acting Normally closed 	10	G 3/8	1.4	0.5...10	300	8	134229
		G 1/2	1.4	0.5...10	300	8	134230
	13	G 1/2	2.5	0.5...10	330	10	132202
		G 3/4	2.5	0.5...10	330	10	282985
	20	G 3/4	5.0	0.5...10	620	16	222478
		G 1	5.0	0.5...10	620	16	222477

1.) Flow rate value for water, measured at +20 °C and 1 bar pressure differential over a fully opened valve.  
 2.) Pressure data: Overpressure with respect to atmospheric pressure, with a differential pressure (difference between inlet and outlet pressure) above half of the nominal pressure there are discontinuities in the valve's characteristics possible.”



### 6.5. Ordering chart accessories

#### Cable plug Type 2518, Form A according to DIN EN 175301 - 803

**Note:**

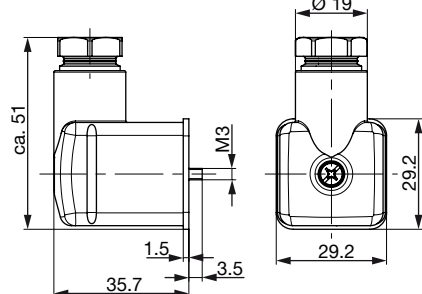

Further versions see data sheet [Type 2518](#) ▶.

Cable plug	Dimensions	Version	Voltage	Article no.
		Without circuitry (AC/DC)	0...250 V AC/DC	314802

#### Control unit Type 8605

**Note:**

Further versions see data sheet [Type 8605](#) ▶.

	Version	Max. coil current range	Type 6223	Type 6223	Article no.
		[mA]	24 V DC	12 V DC	
	Cable plug with PG cable gland	200...1000	x	-	316530
	Cable plug with M12 connection	200...1000	x	-	316528
	Cable plug with PG cable gland	500...2000	-	x	316529
	Cable plug with M12 connection	500...2000	-	x	316526
	Cable plug with PG cable gland without operating element	200...1000	x	-	316521
	Cable plug with M12 connection without operating element	200...1000	x	-	316522
	Cable plug with PG cable gland without operating element	500...2000	-	x	316523
	Cable plug with M12 connection without operating element	500...2000	-	x	316525
	Standard rail	200...1000	x	-	316532
	Standard rail	500...2000	-	x	316533

# Bürkert – Close to You

For up-to-date addresses  
please visit us at  
[www.burkert.com](http://www.burkert.com)

DTS 1000011057 EN Version: K Status: RL (released | freigegeben | validé) printed: 26.03.2021



## Product Enquiry Form - Proportional valve

Thank you for your interest in our products! In order to provide you with optimum advice, please fill out the following form and send it to your **Bürkert representative** or e-mail address: [info@burkert.com](mailto:info@burkert.com). All information submitted will of course be kept strictly confidential.

Please fill in the **required fields!**  \*

\*Note: The interactive functions of this PDF may be restricted depending on the PDF reader used.

Personal Information			
Company		Contact person	
Customer no.		Department	
Street		Postcode / Town	
Telephone no.		Email	

Delivery	
Quantity	Required delivery date

Operating data			
Function <small>(Function of the control valve in the process / process description)</small>			
Operating medium			
Type of medium	Fluid	Steam	Gas
Supply voltage	V		
Ambient temperature (max.)	$t_{u,max} =$	°C / °F	

Fluidic data			
Flow range $Q_{Nom}$	min.	max.	unit
Inlet pressure at $Q_{Nom}$	$p_1 =$	barg <sup>1.)</sup>	
Outlet pressure at $Q_{Nom}$	$p_2 =$	barg <sup>1.)</sup>	
Max. inlet pressure	$p_{1,max} =$	barg <sup>1.)</sup>	
Medium temperature (min./max.)	$t_{m,min} =$	$t_{m,max} =$	°C / °F
Port connection	G (DIN ISO 228/1) Flange	NPT (ANSI B1.2) Other	

1.) Please indicate all pressure values as overpressure to atmospheric pressure [barg] (g = relative pressure)

Material specifications			
Body	Stainless steel	Brass	Other
Seals	FKM	EPDM	Other

Approvals / Conformities
e. g. UL/UR, KTW W270, DVGW Gas, ATEX/IECEX, EAC, etc.

Additional Requirements / Comment

DTS 1000011057 EN Version: K Status: RL (released | freigegeben | validé) printed: 26.03.2021